



VICMARC[®]

**MACHINERY
PTY. LTD.**

OWNER'S MANUAL

VL150

VL200

VL240

VL300

edition 12/16

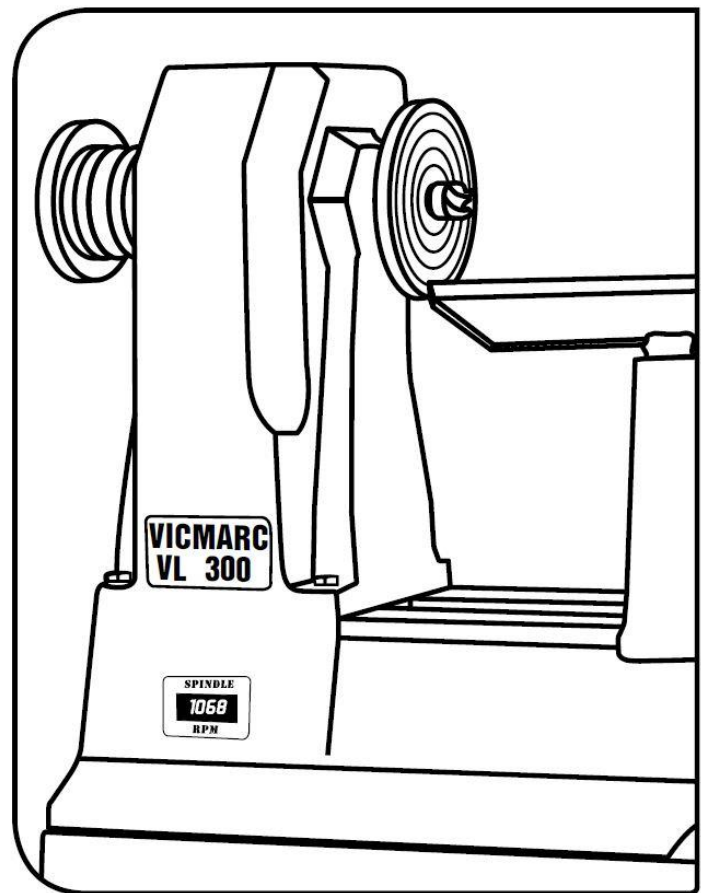











**Manufacturers of
Quality Woodturning Lathes
and Accessories**

within Australia 07 3284 3103
overseas +61 7 3284 3103

www.vicmarc.com



VL150 Series	 <p>VL150 SM EVS</p>	VL200 Series	 <p>VL200 LONG ASM EVS</p>
VL200 Series	 <p>VL200 LONG BED SM 6 SPEED</p>	VL240 Series	 <p>VL240 ASM EVS</p>
VL200 Series	 <p>VL200 SHORT & LONG SM EVS</p>	VL240 Series	 <p>VL240 ASM EVS HEAVY DUTY</p>
VL200 Series	 <p>VL200 SIT DOWN</p>	VL 300 Series	 <p>VL300 SHORT SM EVS</p>
VL200 Series	 <p>VL200 SHORT ASM EVS</p>	VL300 Series	 <p>VL300 SHORT ASM EVS</p>



VICMARC MACHINERY PTY.LTD.

**Manufacturers of Quality
Woodturning Lathes,
Chucks and Accessories**

Phone (07) 3284 3103 Fax (07)32834656
Int Ph 61-7 3284 3103 Int Fax 61-7 3283 4656
Email : vicmarc@vicmarc.com Web www.vicmarc.com
A : 52 Grice Street Clontarf QLD 4019 Australia

Δ Dear Customer

Thank you for purchasing a Vicmarc® high quality wood lathe and accessories. Please read these instructions carefully and familiarise yourself with in every aspect of the lathe before initiating any project. Please keep this manual in a safe place for future reference.

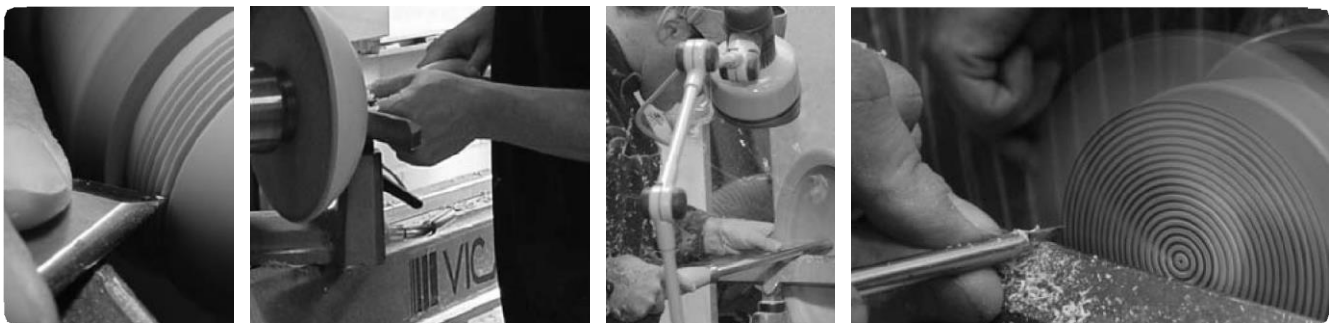

About Vicmarc® Machinery

Vicmarc® Machinery, a family operated business, has been manufacturing wood turning lathes and accessories for the hobbyist and professional since 1984. Director Victor Verrecchia trained in Switzerland in Engineering and Tool Making. Since 1968 he has been designing and manufacturing all types of machinery. Later his focus turned specifically to designing and manufacturing quality Wood Turning Lathes and accessories.

Vicmarc® Lathes and Chucks are known and respected internationally for their unique user friendly design and tough cast iron construction.

Vicmarc® is dedicated in providing to its world wide customers, machinery of the highest quality. Only the best materials and latest high-precision computer-controlled machinery are used in the manufacturing of Vicmarc® Lathes and Accessories.

Vicmarc® machinery continues to respond to the demands of the market, updating and improving at all stages of design and manufacture through constant research and development. It is no wonder therefore that Vicmarc® retains its place as a leader Nationally and Internationally in its field.



Getting Started

1.	SAFETY	1.	Essential Safety Procedures	P5
2.	GETTING STARTED	2.1	Positioning of Your Lathe	P5
		2.2	Cleaning	P5
3.	SET-UP	3.1	The Correct Work Height	P5-6
4.	WORKPIECE SAFETY	4.	Workpiece Diameter And Turning Speeds	P6
5.	GENERAL MAINTENANCE	5.	General Maintenance And Operating Tips	P6
6.	ELECTRICAL INFORMATION	6.	Important Electrical Information	P7
7.	FAMILIARISATION	7.1	Lathe Overview	P7
		7.2	Key Component Description	P8
8.	START UP PROCEDURE	8.	Start up Procedure for your new lathe	P9

Lathe Maintenance Procedures

9.	VL150 LATHE	9.0	Lathe Description	P9
		9.1	Spindle Pulley Speeds	P10
		9.2	Setting Up the Tailstock	P10
		9.3	Setting Up the Camlock	P10
		9.4	Mounting and Removing the Chuck	P10-11
		9.5	Ejecting the Morse Taper	P11
		9.6	Changing the Belt Ratio	P11
		9.7	Replacing the Belt	P11-12
		9.8	Servicing the Tailstock	P12
		9.9	Servicing the Camlock	P13
		9.10	VL150 Exploded Views and Wiring Diagram	P13-16
10.	VL240 LATHE	10.0	Lathe Description	P17
		10.1	Spindle Pulley Speeds	P17
		10.2	Rotating the Index Head	P17
		10.3	Changing the Belt Ratio	P17
		10.4	VL240 Exploded Views and Wiring Diagram	P18-19
11.	VL200/300 LATHE	11.0	Lathe Description	P20
		11.1	Spindle Pulley Speeds	P20
		11.2	VL200/300 Exploded Views and Wiring Diagram	P20-22
12.	VL200/240/300 LATHE	12.1	Setting Up the Tailstock	P24
		12.2	Ejecting the Morse Taper	P24
		12.3	Servicing the Tailstock	P24-25
		12.4	Setting Up the Camlock	P25
		12.5	Servicing the Camlock	P25
		12.6	Setting Up the Safety Ring	P25
		12.7	Changing the Belt Ratio	P25
		12.8	Mounting and Removing the Chuck	P26
		12.9	Outboard Turning Set Up	P26
		12.10	Replacing the Belt	P27

General Information

13.	TROUBLESHOOTING			P28
14.	LATHE SPECIFICATIONS			P29
15.	TECHNICAL INFORMATION			P30

1. SAFETY

- 1. READ AND UNDERSTAND THE INSTRUCTION MANUAL BEFORE OPERATING WOOD LATHE.**
- Do not operate while under the influence of drugs, alcohol or medication.
- Switch main power off when machine is not in use.
- The power supply to the electronic unit needs to be turned off when not in use
- Do not attempt to turn without having had some woodturning lessons.
- Do not wear gloves, neckties, jewellery or loose clothing.
- Always wear eye protection and a dust mask.
- Do not operate without guards in place. Always close the cover before operating.
- Rough out the work piece before installing on the faceplate.
- Do not mount a split work piece or one containing knots.
- Tighten all camlocks before operating.
- Ensure the work piece does not move on the mount while it is being turned.
- Ensure that the indexing pin is disengaged by rotating the work piece by hand before applying power.
- Use low RPM when starting a new work piece and do not exceed permitted Rpm (Revolutions per minute). (Refer to page 6 under Workpiece Diameter & Turning Speeds).
- Allow the lathe to come to a complete stop before changing direction of turning.
- Disconnect machine from power source before proceeding with any maintenance or any adjustments.
- Ensure the switch is in the OFF position before plugging into the power source.
- Remove the tool rest, or move the camlock to the side before sanding or polishing.
- If available we recommend using a dust extraction apparatus.

2. GETTING STARTED

2.1 The Positioning of Your Lathe

- Before unpacking your lathe, decide where it is to be placed and clear the floor area. Preferably choose a level area, with sufficient room around for any maintenance required. (recommended is 800mm clearance all around).
- Confirm that you have a suitable power outlet close to the chosen lathe location eliminating any unnecessary extension leads. (Refer to "IMPORTANT ELECTRICAL INFORMATION" Item 6, page 7)
- Position your lathe after unpacking in the designated area.
- Set-up your lathe to your correct work height according to the recommendations made in the correct workheight in item 3.1, pages 5-6.
- It is not always necessary to anchor down the lathe, as the weight of the lathe will be sufficient to hold it down in most applications. Anti-vibration pads under each leg are recommended to minimise vibration and floor damage. For your personal safety, it is recommended to anchor down your lathe.

- If lathe is to be anchored to the floor, anti vibration pads such as rubber or carpet pieces should be used
- Place spirit level on your lathe bed. Make it level by adjusting the levelling screws on each corner of the lathe.
- It is recommended to use M10 concrete anchor bolts to anchor the lathe. (Refer below)
- After satisfactory position and levelling has been achieved, tighten the locknuts. (Refer below)
- Be cautious not to twist the machine by tightening the anchor bolts when the machine has not levelled first.

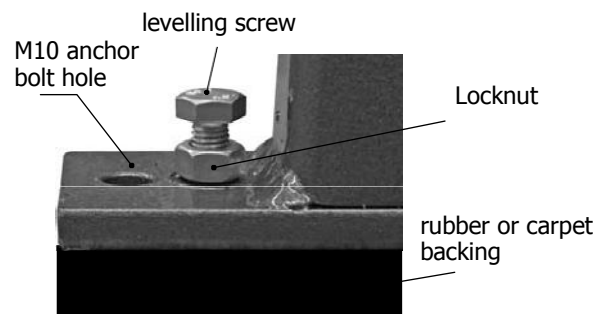

2.2 Cleaning

- The Manufacturer Vicmarc® Machinery has applied a thick corrosion protective coating to ensure the lathe reaches you in optimum condition. Use white spirits or similar product to remove the protective coating.
- In order to keep the machine in top condition, spray all exposed metal areas with light viscosity oil. This minimises corrosion.
- To ensure maximum longevity for your machine, remove all sawdust then re-oil the surfaces after every use.

3. SET UP

3.1 The Correct Work Height

- The correct height of the lathe is important. It not only minimises fatigue but it also increases the safety aspect for the user and encourages comfortable turning.
- The work height is different for every user.
- The work height is also dependant on the type of work performed.
- The recommended work heights are as shown below.

3. SET UP

3.1 The Correct Work Height

Height of Operator		Calculated Work height	
160cm	63"	100cm	39"
165cm	65"	102.5cm	40"
170cm	67"	105cm	41"
175cm	69"	107.5cm	42"
180cm	71"	110cm	43"
185cm	73"	112.5cm	44"
190cm	75"	117.5cm	46"
195cm	77"	120cm	47"

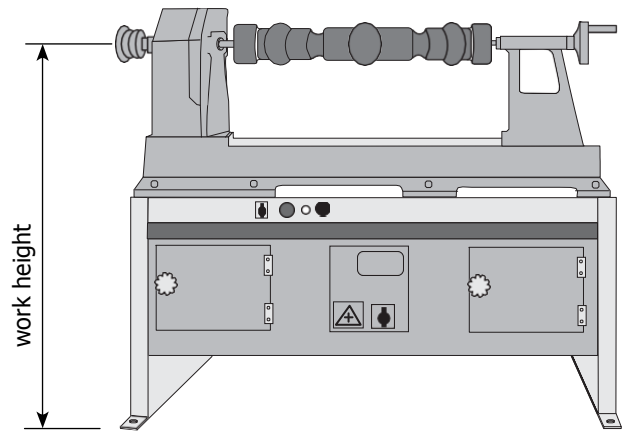

Note. The Subjective Preference of the Turner

The above results in table one were achieved from a study of 4500 turners the following guide can be used in setting up your lathe. As a rule of thumb use the height of the turner and subtract 60-75cm (= the recommended work height. You may wish to use your personal preference. The above table one should be used as a starting point. **For all machine models, calculated work height is measured from the floor to the centre of the spindle.**

4. WORKPIECE TURNING DIAMETER and TURNING SPEEDS

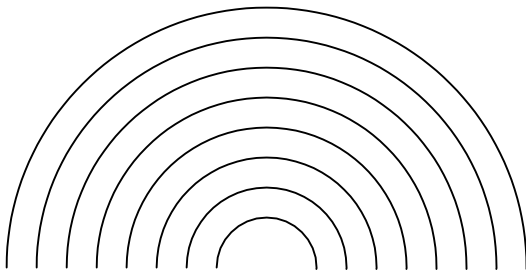

Ø 450mm	400rpm
Ø 400mm	500rpm
Ø 350mm	550rpm
Ø 300mm	650rpm
Ø 250mm	800rpm
Ø 200mm	1000rpm
Ø 150mm	1300rpm
Ø 100mm	2000rpm

Caution!

The turning speeds are only to be used as a general guide and are starting speeds for your work piece. Due to different wood types and wood thicknesses etc. different speeds may be necessary for optimal and safe turning.

5. GENERAL MAINTENANCE AND OPERATING TIPS

1. IMPORTANT.

Refer to item 6 electrical information below.

- All EVS machines come with a 220 – 240V AC inverter. Settings for the unit have been programmed to suit the lathe that it was fitted to and should not be tampered with. Tampering with the inverter unit will void all warranty claims.
- Make sure that the lathe is positioned level on the workshop floor. It is important that rubber padding or carpet is placed under the steel stand to separate it from the floor to reduce vibration. The lathe may be bolted to the floor if required. If bolting the lathe to the floor, make sure that the lathe stand sits level to the ground. (Refer to levelling your lathe page 5)
- Ensure the switch is in the OFF position before plugging into the power source.
- Before starting the lathe make sure the indexing pin is not engaged to prevent the drive belt from being damaged.
- If turning inboard clockwise or outboard anti-clockwise, use the safety ring (Refer to Setting up the safety ring 12.6, Page 25) in order to prevent your work piece from coming undone.
- Note.** If the spindle overheats (too hot to touch), engage the indexing pin, loosen the three grub screws, back off the bearing adjustment nut (handwheel on the VL100) by rotating 2-5 degrees anticlockwise, retighten the grub screws evenly. Once tight, disengage the indexing pin and turn the spindle by hand making sure that the spindle turns freely without any tight spots.
- Before turning, always manually rotate the work to ensure that it clears all parts of the lathe.
- Do not over tighten the belt. Tighten with a deflection of 10-15mm.
- When engaging the indexing pin, do not use excessive force to remove or tighten any of the faceplates or chucks.
- It is not recommended to run the lathe for an extended period of time at low rpm as this could cause overheating and although the motor has thermal protection, abuse can still damage the motor.
- If the motor trips out from overheating, allow it to cool for 15-20 mins before continuing turning.
- If the lathe is not to be used for an extended period of time, it is recommended that the lathe be disconnected from the power source/mains supply.

6. IMPORTANT ELECTRICAL INFORMATION



DANGER
electric
shock risk

1. Please ensure that the circuit for the power outlet is earthed and protected by at least a 15-20 - amp circuit breaker.
2. The lathe electronics is provided with an RFI (**R**adio **F**requency **I**nterference) filter which is designed to leak up to 5 milliamps. Due to earth leakage of more than 15 milliamps from other appliances in the same circuit tripping may occur. That is why it is recommended that a dedicated power circuit for the lathe be installed.
3. Some brands of earth leakage switches are more susceptible to the conducted RFI. If excessive tripping still occurs when the lathe is on a separate circuit then contact your local electrician. The electrician can check with the supplier of the earth leakage switch, checking its suitability for the use with single phase supply output AC Variable Speed Drives.
4. We strongly recommend any work on your power supply to the lathe or the electrical system of the lathe should be performed by a qualified and licensed electrician.
5. For optimum results make sure that the lead to the power supply is no longer than three meters. Leads longer than three meters can cause amperage-rating fluctuation and affect the lathes performance.

7. FAMILIARISATION





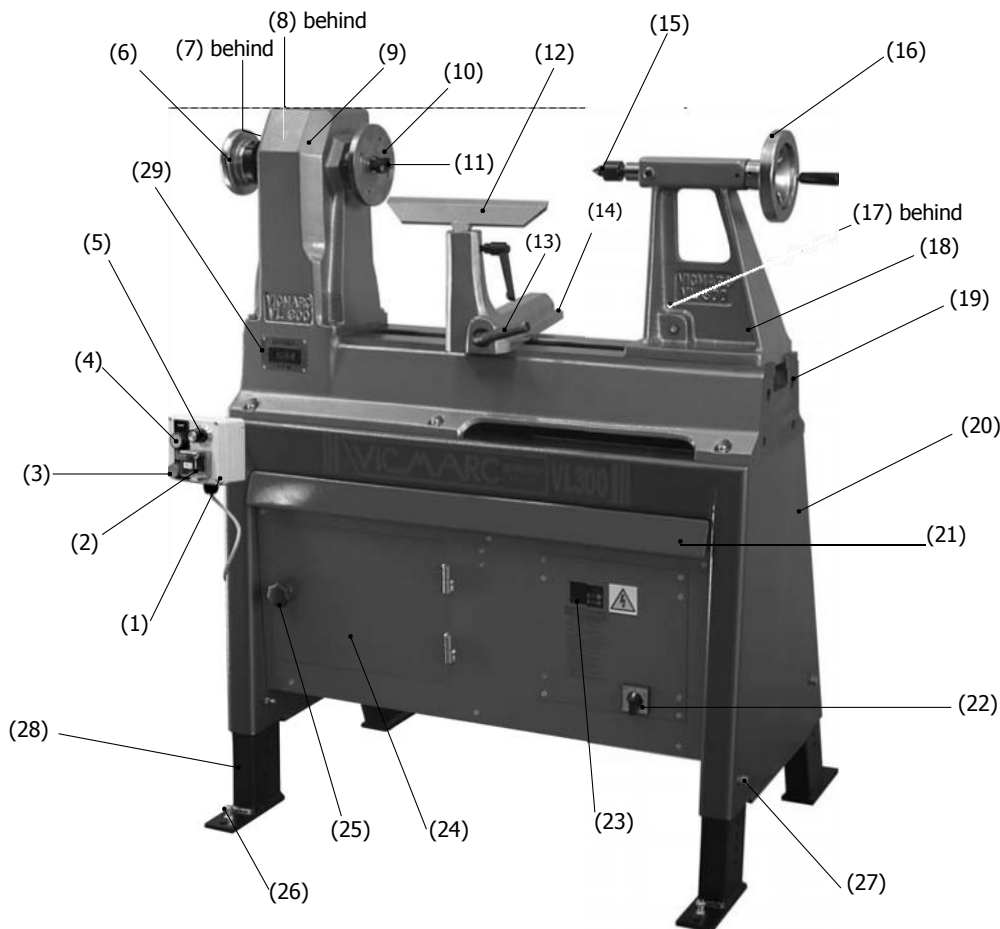



7.1 Overview

- Before starting to use your Vicmarc® Lathe it is important that you familiarise yourself with all aspects and parts of the lathe. The below picture will give you a parts description.



No.	Description	No.	Description	No.	Description
1	Remote Switch Box	11	Drive Dog	21	Stop Bar
2	Reverse Button	12	Toolrest	22	Main Switch
3	Off Button	13	Camlock Locking Lever	23	Digital Display Unit (electronic models only)
4	On Button	14	Camlock	24	Motor Access Door
5	Speed Controller	15	Live Centre	25	Motor Access Door Lock
6	Handbrake Wheel	16	Hand Wheel	26	Lathe Levelling Bolts
7	Indexing Pin	17	Tailstock Locking Lever	27	Height Positioning Bolt x 4
8	Indexing View Glass	18	Tailstock	28	Adjustable Legs
9	Headstock	19	Bed	29	RPM LED Display
10	Faceplate	20	Stand		

7.2 Key Component Description (items refer to page 7, 7.1 overview)

 <p>Item 2 - Reverse Button This button enables you to turn in reverse. However it is important that when choosing to turn in reverse you make sure the lathe has come to a complete stop. Caution, use the safety ring as described on page 25 when reverse turning. The quality of sanding can be improved and provide a smoother finish by altering the direction of rotation.</p>	 <p>Item 3 / 4 - On & Off Buttons Before starting your lathe, rotate your work piece one rotation using the Handbrake Wheel (Item 6). This will ensure the work piece has sufficient clearance. If the work piece does not rotate, make sure the indexing pin (Item 7) is disengaged. The lathe has a soft start of 3 seconds and a 4 second stop. These settings should not be changed as these have been factory set for your safety.</p>	 <p>Item 5 - Speed Controller Is used to adjust the speed of the lathe, 0 – slowest 10 – fastest, actual motor speed displayed on the digital display unit (Item 22)</p>
 <p>Item 7 - Indexing Pin To engage the indexing pin rotate the head of the pin 90° until it slides inwards, then rotate the handbrake wheel (item 6) until the pin engages preventing the spindle from rotating. To disengage pull out the pin and rotate the head 90°.</p>	 <p>Item 8 - Index Viewing Glass All lathes have 24 indexing holes in the back of the spindle, which are used for indexing and locking the spindle. Each hole represents 15 degrees for indexing purposes.</p>	 <p>Item 21 - Stop Bar Designed for safety and to be controlled primarily by the operator's leg. It works the same as the Off Button (Item 4).</p>
 <p>Item 22 - Main Switch This switch disconnects all power to the lathe and should be turned off when the machine is not in use.</p>	 <p>Item 23 - Digital Display Unit This displays the speed of the motor and is controlled by the Speed Controller (Item 5). For actual spindle speeds available refer to "Spindle Speed" under your lathe model.</p>	 <p>Item 29 - RPM LED Display This displays the speed of the spindle and is controlled by the Speed Controller (Item 5).</p>

8. START UP PROCEDURE FOR YOUR LATHE

Important. Remember your safety is a priority!

- Ensure you have set up your lathe correctly as per page 5 and that you have connected your power lead from the lathe to the nearest power point as per "important electrical information" on page 7
- Turn the main switch (item 22) clockwise (see page 7 for location).
- By now the EVSD (electronic variable speed device) will give a digital readout by flashing. (item 23 page 7)
- You can now select the rpm required by adjusting the speed controller (potentiometer) (item 5) . The rpm you select will appear flashing on the digital readout.
- Please ensure that the spindle is not locked with the indexing pin (item 7 on page 7).
- After placing your work piece first make sure it can be rotated by hand. Start up your lathe on low rpm. Refer to work piece diameter and turning speed information on page 6.

IMPORTANT: For the work piece diameter and turning speeds you must familiarize yourself with the information on page 6. The spindle pulley ratio information is near the beginning of the section for your particular lathe.

- Depress the on button (item 4 on page 7) this will introduce power to the motor and activate the lathe. Note: the rpm, which is displayed, is the rpm at which the motor is currently operating.
- Because of different densities within the timber, we recommend to gradually increase your speed as your work piece allows, without allowing your lathe to vibrate.
- Increased vibration can cause work piece to come off its holding position.
- For extra safety use tailstock with live centre to support work piece.
- The electronic motor will reach its selected speed within three seconds, and it will take only 4 seconds to come to a full stop.
- **WARNING:** Do not attempt to stop manually with your hand the break wheel within the 4 seconds as it can cause skin burn.
- To stop your lathe the stop bar can be used. Refer to item 21 on page 7.
- Please refer to the safety instruction on page 5 and safety ring set up on page 25.

9. LATHE VL150



VL150BM 6SP



VL150SM EVS

Description

The Vicmarc® mini lathe was the first to introduce the MT2, and taper roller bearings on this size lathe and is in a class of its own when compared to other mini lathes on the market. The cast iron bed and headstock are stronger than many full-size lathes. Vicmarc® is clearly the mini lathe of choice. The best value feature-by-feature of any mini lathe sold in the world. This lathe is made to last a lifetime.

The VL150 has optional bolt on extension facility for increased distance between centers.

9. LATHE VL150

9.1 Spindle Pulley Speeds

It is important that the belt is on the right pulley for the speed required. Not doing so can cause the motor to overheat. Below is a representation of the headstock pulleys and their equivalent ratio's.

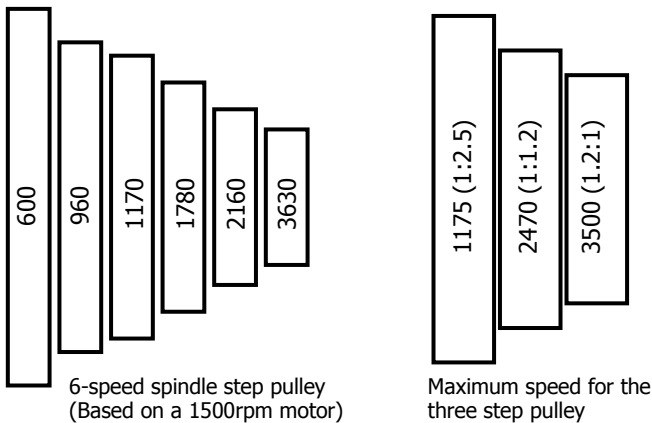

	Pulley Ratio		
Readout	1.2:1	1:1.2	1:2.5
3000	3500	2470	1175
2500	2917	2058	979
2000	2333	1647	783
1500	1750	1235	588
1000	1167	823	392
500	583	412	196
250	292	206	98
100	117	82	39
30	35	25	12

9.2 Setting up the Tailstock

The eccentric locking mechanism of the tailstock is factory preset. If adjusting is necessary the following steps are applicable:

- Slide tailstock to the end of the bed as illustrated.
- Undo the M10 locking nut item 14 (clockwise is loosening and anticlockwise is tightening) with an 16mm open end spanner, then rotate the clamping plate clockwise to tighten.
- Lock the Tail stock with locking lever, if lever is in the correct position is at eleven o'clock Re-lock the locking nut.
- The tailstock lever can be swapped to the opposite side of the tailstock if preferred. Simply remove the circlip and reposition the bush and tailstock locking lever to the opposite side.

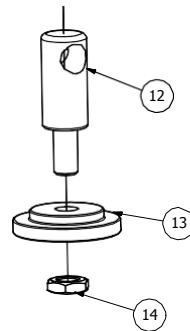

9.3 Setting up the Camlock

The eccentric locking mechanism of the Camlock is factory preset. If adjusting is necessary the following steps are applicable:

- Remove Tailstock then slide Camlock to the end of the bed as illustrated.
- Undo the M10 locking nut item 7 (clockwise is loosening and anticlockwise is tightening) with an 16mm open end spanner, then rotate the clamping plate clockwise to tighten.
- Lock the Camlock with locking lever, if lever is in the correct position is at four or eight o'clock, re-lock the locking nut. (Camlock is designed to lock in both directions)

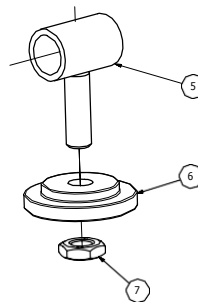

9.4 Mounting and Removing the Chuck

Mounting

Before mounting the chuck, make sure that the threads are clean and free of grit.

- Place the tommy bar (supplied with Vicmarc® Chuck) into the spindle to hold it in place.
- Mount the chuck on the lathe, carefully place the chuck on the thread, making sure it is square.
- Turn the chuck slowly to screw on the chuck until it is tight.
- The machine should never be turned on for this procedure.



9. LATHE VL150

9.4 Mounting and Removing the Chuck

Removing

- Place the tommy bar into the spindle to hold it in place as in mounting.
 - Place the other bar into the chuck and push firmly to unbind the chuck thread.
 - Use a light tap with the hand or a soft mallet (never use a metal one) to unbind the thread if necessary.
 - Once the thread is unbound unwind the chuck while holding the spindle secure with the tommy bar.
- **Tip:** If you have continued problems removing the chuck, a thin pvc (nylon) washer can be between the face of the chuck and the face of the spindle before the chuck is screwed on. This prevents metal to metal binding which can make it difficult to remove the chuck.



9.5 Ejecting the Morse Taper

The taper is removed by using the knock out bar. The knock out bar is placed into the end of the tailstock and taps the taper out (a soft hammer can be used on the knock out bar if necessary).

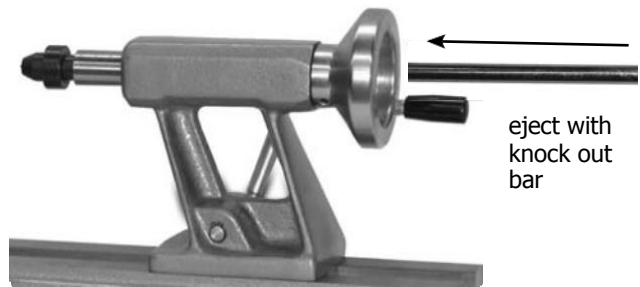

9.6 Changing the Belt Ratio

Depending on the size of the work piece to be turned (see Turning Diameter and Turning Speeds Page 6) the belt ratio may require changing for different speeds.

- Before commencing any maintenance work on the machine, make sure that the main switch is in the off position.
- Loosen the clamp lever and lift up the motor to loosen the belt.
- Once loosened, seat the belt precisely on the correct pulley ratio.
- Re-tension the belt.



9.7 Replacing the Belt

Removing the Belt:

- Make sure that the lathe is turned off at the main switch.
- Measure the distance between the largest pulley and the inside of the headstock so that the pulley can be re-installed at the exact same original position.
- Loosen the belt as per changing the belt ratio.
- Loosen the grub screws on the handbrake wheel.
- Engage the indexing pin and unscrew the handbrake wheel clockwise and remove.
- Loosen the grub screw on the middle-sized pulley with an Allen key.
- From the hand wheel side, lightly tap the spindle with a rubber mallet making sure that it stays horizontal avoiding damage to the key way.
- Ensure that the taper roller bearing on the handbrake wheel side does not fall out.
- Remove the spindle ensuring that the pulleys are not allowed to drop down into the headstock.
- Place the spindle in a clean place and pull out the pulley.
- The belt can now be removed, making way for a new belt.

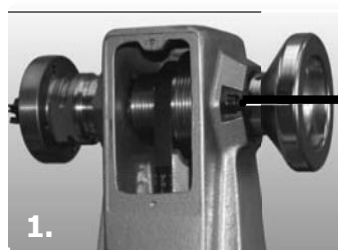

1.

index pin



2.



3.



4.

9. VL150 LATHE

Re-Assembly of the Belt

- Sit the new belt on the pulley and place back into headstock.
- When re-inserting the spindle, make sure that the key on the spindle lines up with the keyway to avoid any damage.
- Line up the pulley back in its original position and re-tighten the grub screw in the middle pulley.
- Screw the handbrake wheel back on until there is no axial play in the spindle and tighten the grub screws.
- Hook belt around the motor pulley and tighten the belt adjustment. Check the belt deflection to ensure the correct tension. (see page 17)
- Once assembled replace all covers, disengage the indexing pin and turn spindle by the hand wheel to check for hard spots.
- Turn the machine on at the mains switch and run the machine at moderate Rpm (approx 1500 rpm) for five minutes to check the operation of the machine.
- If the pulley housing gets hotter than luke warm to touch after 5 minutes of operation then stop the machine, loosen the handwheel grub screws and unscrew the handbrake wheel approx 2 to 5 degrees then re-tighten the grub screws.

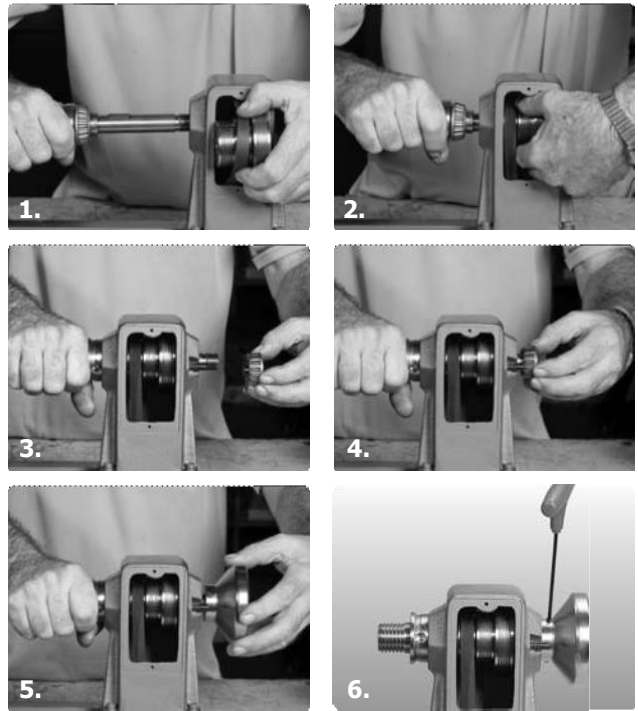

9.8 Servicing the Tailstock Removing the Quill on the Tailstock:

- Lock the tailstock onto the bed using the locking lever.
 - Turn the hand wheel so that 20-25mm of the quill is protruding from the front of the tailstock.
 - Loosen the grub screws on the handle two or three revolutions.
 - Pull off the handwheel.
 - Loosen the nuts on both sides of the tailstock, then remove the grub screws.
 - The quill can now be removed from the tailstock
 - The quill can now be cleaned along with the inside of the tailstock.
- **Note.** Never use sandpaper to clean the quill and take care not to remove the **key piece** at the end of the locking lever while cleaning.
- All mobile parts should now be greased with a high quality grease or graphite grease before re-assembly.

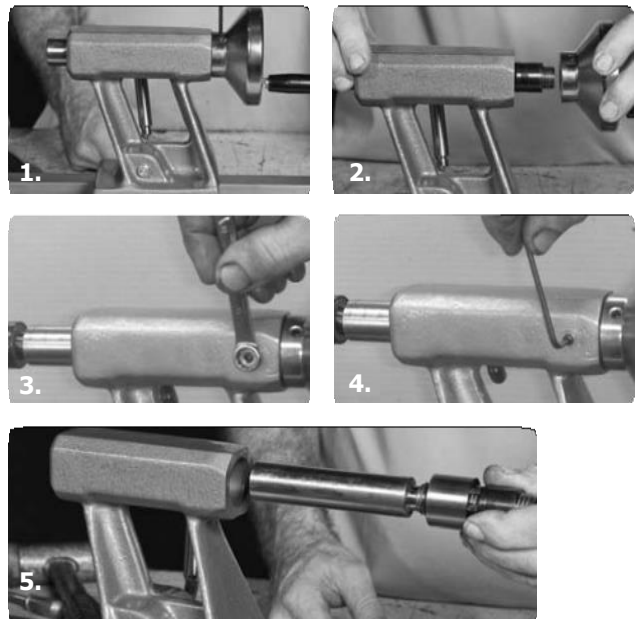

Re-Assembling the Quill on the Tailstock:

- The quill should be re-placed from the back of the tailstock making sure that it is horizontal to the bore.
- Push the quill back into place and align the keyway into the key piece.
- Realign the drill marks in the tailstock bush to the grub screw holes and retighten the grub screws equally. Then retighten both nuts.
- Replace the hand wheel and tighten the grub screws.
- Turn the hand wheel. If it does not run smoothly (i.e. slight gripping or scraping) several light taps on the hand wheel with rubber hammer will bring the quill into alignment.
- The free play of the hand wheel should be no more than 10 degrees.

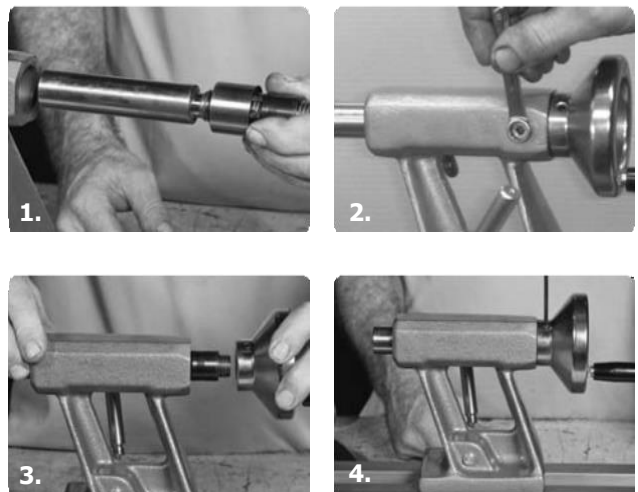

9. LATHE VL150

9.9 Servicing the Camlock (see view below)

- Undo the two circlips (item 4).
- Reach underneath and support the clamping plate. (item 6)
- Slide out the camlock bar. (item 8)
- Thoroughly clean the shaft and the bore.
- Re-grease the shaft with a high quality bearing grease.
- To re-assemble, slide in the shaft through the bore and the camlock T-Connector (item 5).
- Replace the circlips.



9.12 VL150 Exploded Views - Camlock

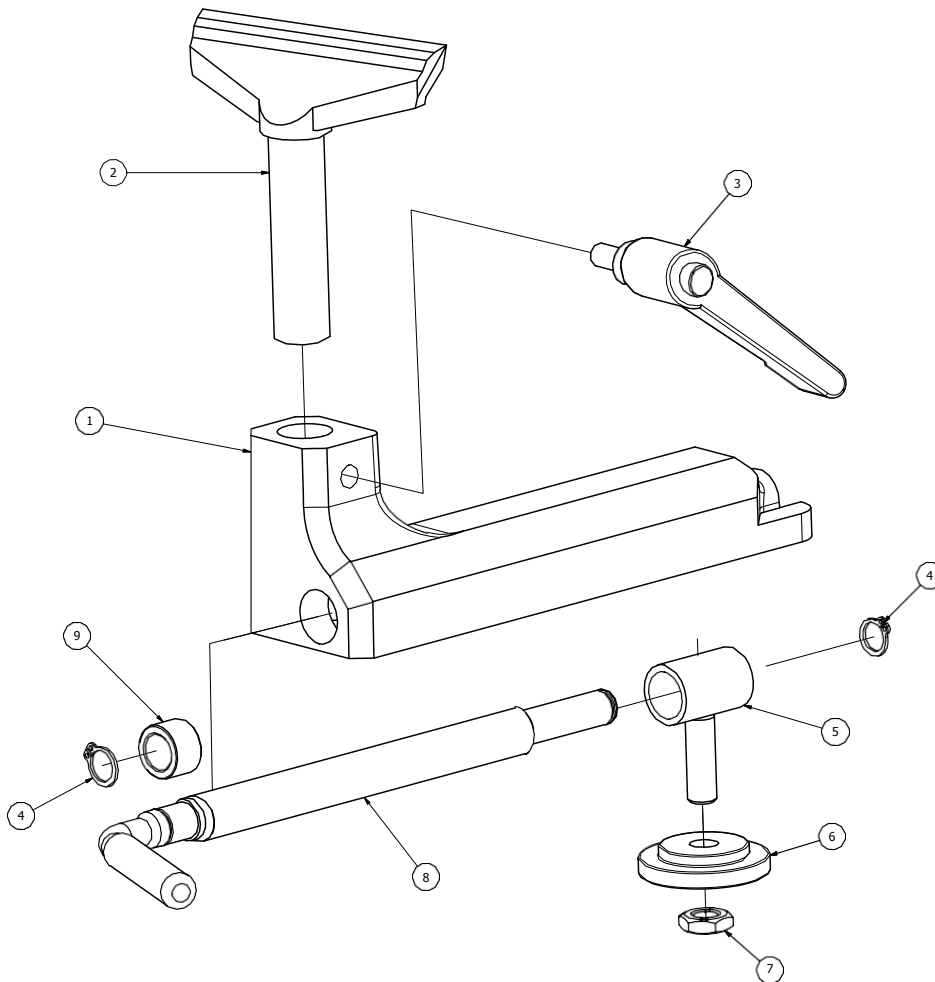

VL150 Camlock			
No.	Qty	Part No.	Description
1	1	V00196	Camlock
2	1	V01164	Toolrest, 150mm
3	1	P00398	Adjustable Handle, M8 x 20
4	2	P00242	Circlip, External 12mm
5	1	V00305	Camlock T- Connector
6	1	V00905	Clamping Plate, 31mm
7	1	P00510	Hex Nut, M10
8	1	V00790	Camlock Lever
9	1		Camlock Lever Bush

9. VL150 LATHE

VL150 Stand

No.	Qty	Part No.	Description
1	1	-	VL150 Stand
2	2	P00695	Pan Head Screw, M4 x 10
3	2	-	Door Hinge
4	1	-	Door Knob
5	1	-	Motor Door
6	4	P00122	Cup Head Bolts, M8 x 20
7	9	P01200	Washer, M8
8	5	P00517	Hex Nut Nylock, M8
9	1	P00396	Adjustable Handle Female, M8
10	1	-	Motor Bracket
11	1	-	Motor Pulley
12	1	P00741	Socket Set Screw, M6 x 10
13	4	P00727	Socket Hd Countersunk Screw M6 x 16
14	1	-	Motor Mount Flange
15	1	P00457	0.55kW Motor
16	2	P00211	Cable Gland, 19mm
17	1	-	Inverter Cover
18	12	P00506	Hex Nut, M4
19	12	P01194	Washer, M4
20	1	-	Inverter Bracket
21	1	-	RFI Filter
22	1	P00642	Reverse Button
23	1	P00640	Stop Button
24	1	P00641	Start Button
25	1	P00631	Speed Controller
26	1	-	Inverter, 0.75KW
27	1	V00187	Bed
28	4	P00735	Socket Head Cap Screws, M8 x 35

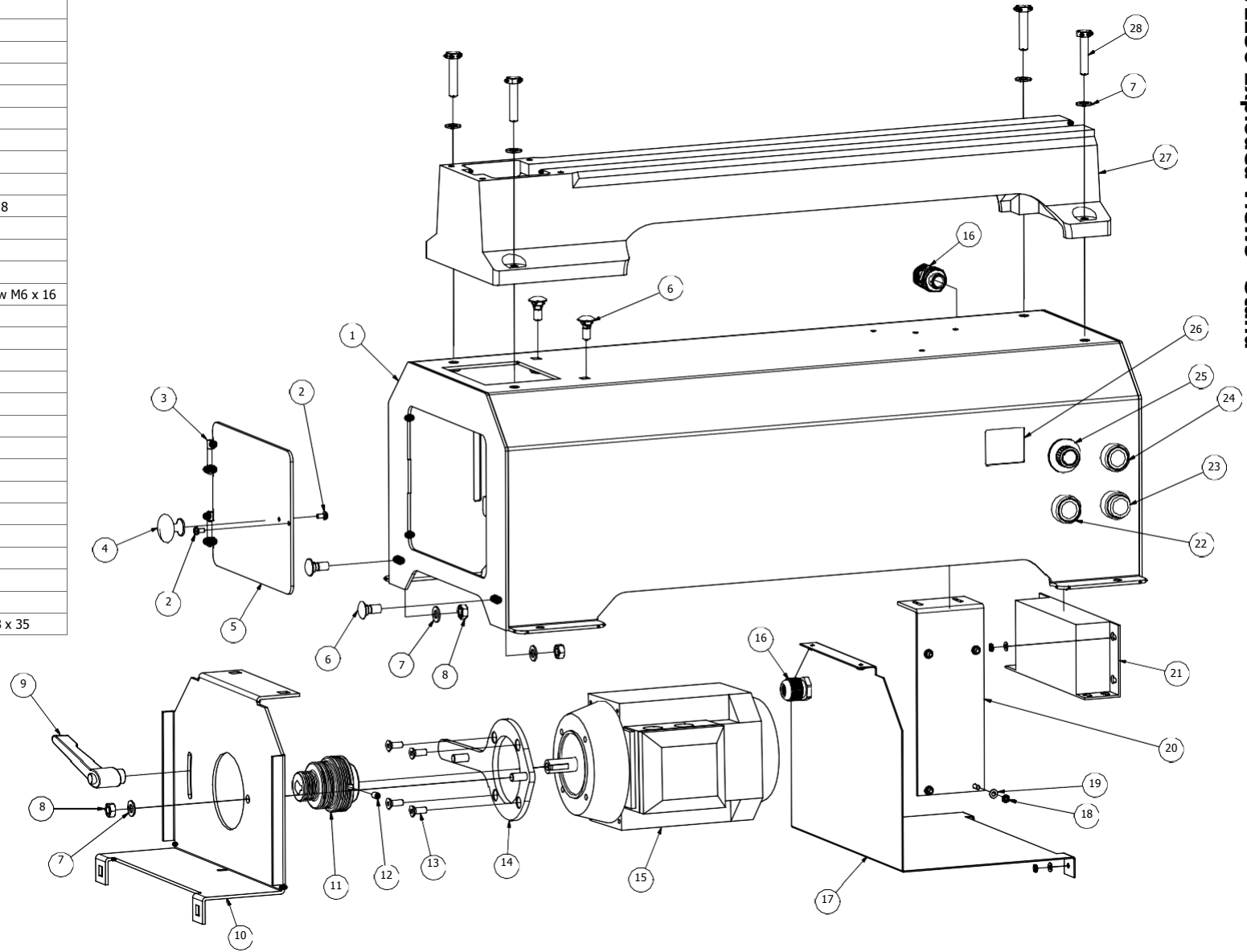

9. LATHE VL150

9.10 VL150 Exploded Views - Headstock

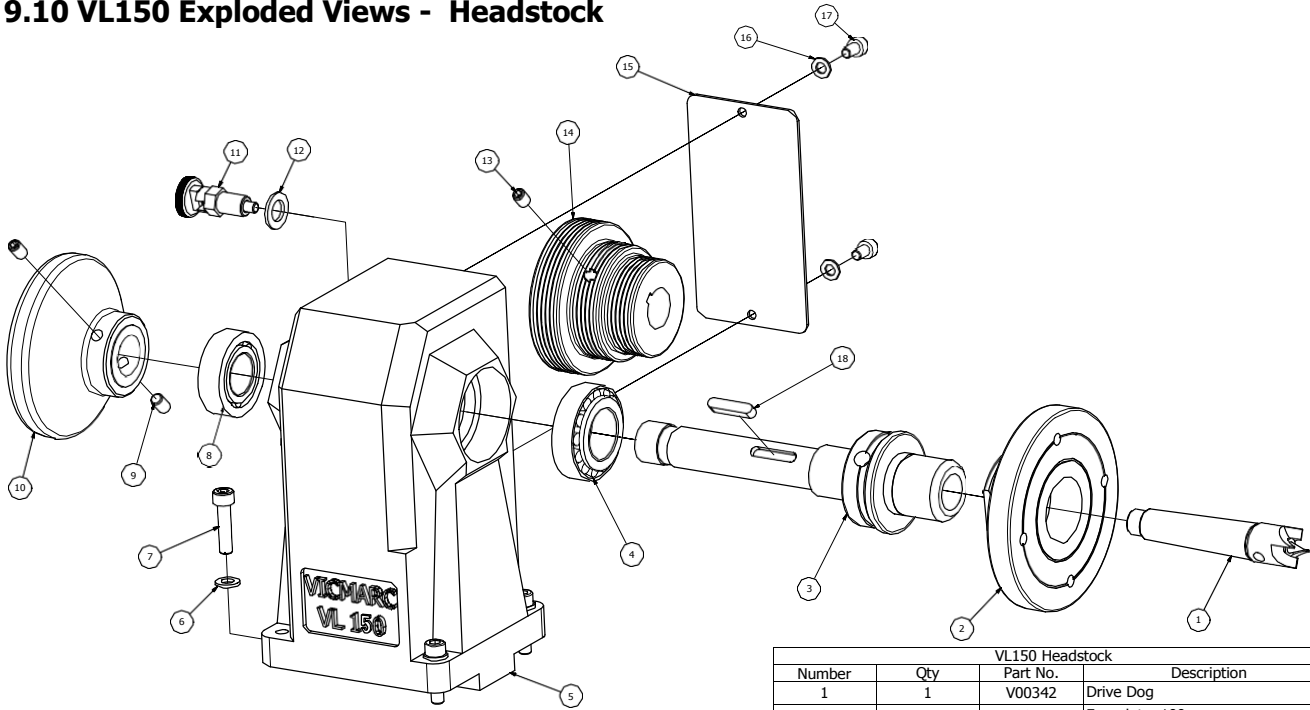

VL150 Headstock			
Number	Qty	Part No.	Description
1	1	V00342	Drive Dog
2	1	V00411	Faceplate, 100mm
3	1	V01046	Headstock Spindle
4	2	P00071	Bearing, Taper Roller 32005
5	1	V00460	Headstock
6	4	P01198	Washer, M6
7	4	V00733	Socket Head Cap Screw M6 x 25
8	1	P00070	Bearing, Taper Rpller 32004
9	2	P00741	Socket Set Screw, M6 x 10
10	1	V00445	Handbrake Wheel
11	1		Indexing Pin Assembly
12	1	P01203	Washer, M10
13	1	P00740	Socket Head Set Screw, M6 x 8
14	1	V00920	Headstock Pulley
15	1	V00322	Headstock Cover
16	2	P01194	Washer, M4
17	2	P00731	Socket Head Cap Screw, M4 x 10
18	1	V00711	Key, Headstock Spindle

9.15 VL150 Exploded Views - Tailstock

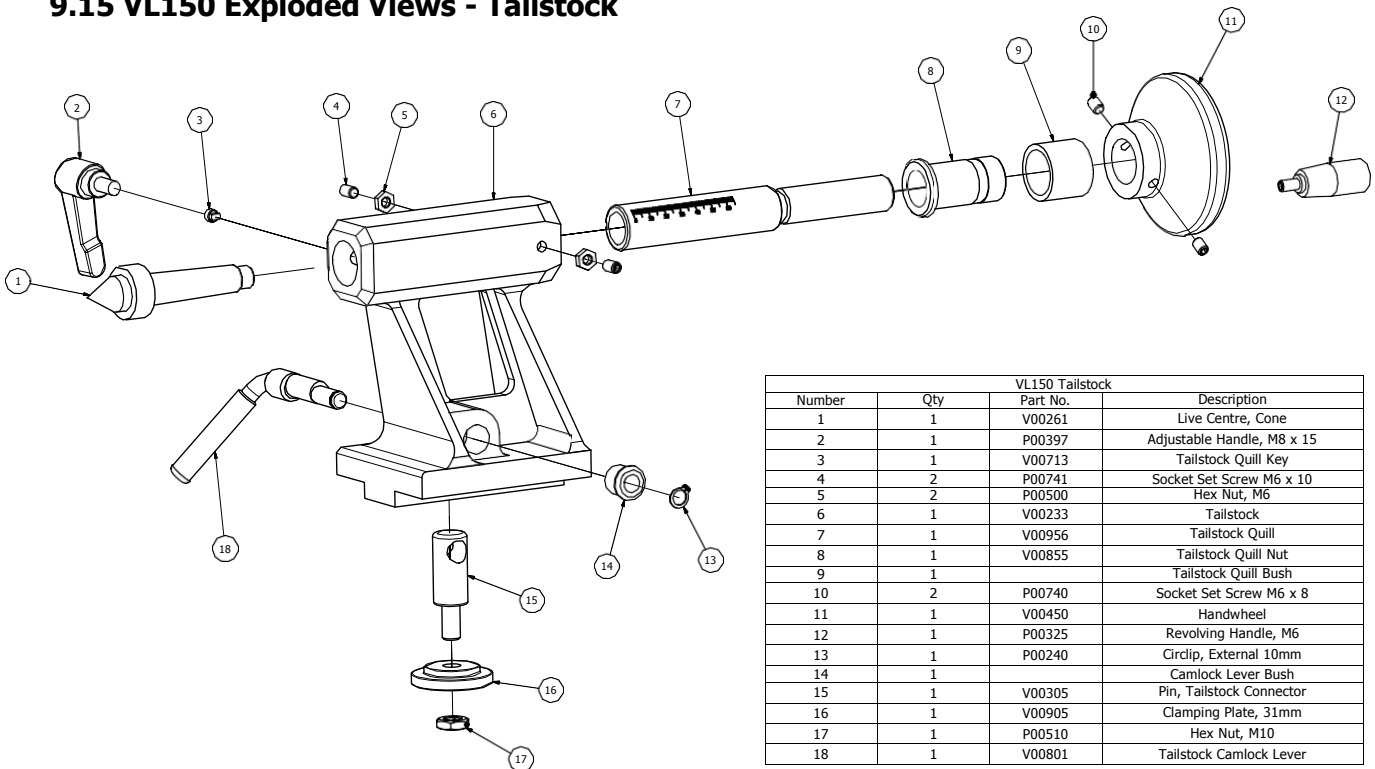

VL150 Tailstock			
Number	Qty	Part No.	Description
1	1	V00261	Live Centre, Cone
2	1	P00397	Adjustable Handle, M8 x 15
3	1	V00713	Tailstock Quill Key
4	2	P00741	Socket Set Screw M6 x 10
5	2	P00500	Hex Nut, M6
6	1	V00233	Tailstock
7	1	V00956	Tailstock Quill
8	1	V00855	Tailstock Quill Nut
9	1		Tailstock Quill Bush
10	2	P00740	Socket Set Screw M6 x 8
11	1	V00450	Handwheel
12	1	P00325	Revolving Handle, M6
13	1	P00240	Grip, External 10mm
14	1		Camlock Lever Bush
15	1	V00305	Pin, Tailstock Connector
16	1	V00905	Clamping Plate, 31mm
17	1	P00510	Hex Nut, M10
18	1	V00801	Tailstock Camlock Lever

9. VL150 LATHE

9.10 VL150 - Wiring Diagram

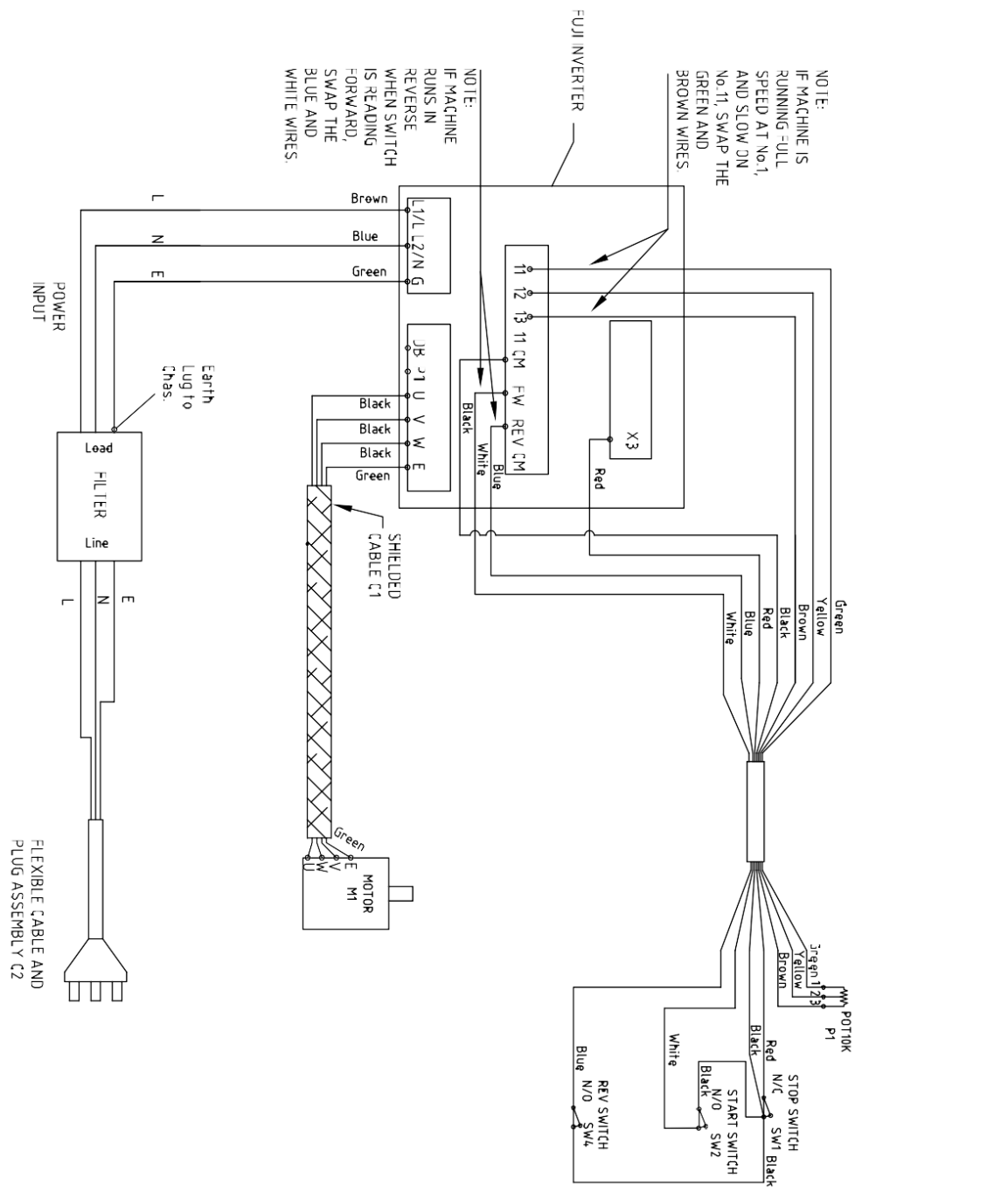

9. VL150 LATHE

No. of Pieces	SPECIFICATION	POS.	MATERIAL	MODEL	OBSERVATIONS
MODIFICATIONS:				Replaced from:	
VL150 WIRING FUJI 0.75 C1S-7A				SCALE	Drawn: M.R. Date: 20.11.12
				NTS	Checked: Date:
				DWG No. WIRING 10D	

10. LATHE VL240



VL240 ASM EVS HEAVY DUTY



Electronic Unit



Control Box

Flat Pack Stand can also be purchased separately.
Part No. V01082

Lathe Models 200,240 and 300 are equipped with the same headstock spindle, tailstock spindle, handwheels, handbrake wheels and bearings. Therefore all adjustments and assembly methods on the headstock and the tailstock on those models are the same. The camlock assemblies are of the same system but different sizes.

10.1 Spindle Pulley Speeds

It is important that the belt is on the right pulley for the speed required. Not doing so can cause the motor to overheat. Below is a representation of the headstock pulleys and their equivalent ratio's.

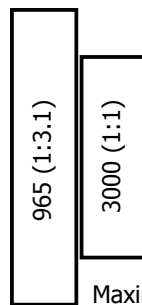

Maximum speed for the two step pulley

	Pulley Ratio	
Readout	1:1	1:3.1
3000	3000	965
2500	2500	804
2000	2000	643
1500	1500	483
1000	1000	322
500	500	161
250	250	80
100	100	32
30	30	10

10.2 Rotating The Index Head

- Undo the headstock-locking lever.
- Lift the headstock-locking pin.
- Swivel the headstock to preferred angle in a clockwise direction (indexed at 30 degree increments - 0°, 30°, 60° and 90°).
- Re-insert the headstock locking pin.
- Relock the headstock-locking lever after making the adjustment.
- **Important:** Make sure the locking lever is in locked position when lathe is in operation.



10.3 Changing the Belt Ratio

Depending on the size of the work piece to be turned (see Turning Diameter and Turning Speeds Page 6) the belt ratio may require changing for different speeds.

- Before commencing any maintenance work with the machine, make sure the mains switch is in the off position.
- Adjust the Headstock so that the spindle is parallel to the lathe bed.
- Unscrew the motor pulley cover and remove.
- Loosen the locking handle and lift the motor to release the belt tension.
- Once loosened, seat the belt precisely on the correct pulley ratio.
- Re-tension the belt with a maximum deflection of 10-15mm (do not over tighten as it can cause motor bearing problems) see page 17.
- Re-tighten the locking handle.
- Replace all covers before turning machine on.

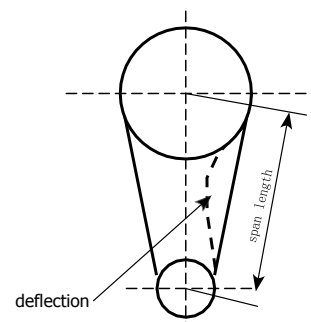

10. VL240 LATHE

10.4 VL240 Exploded Views - Camlock - Tailstock

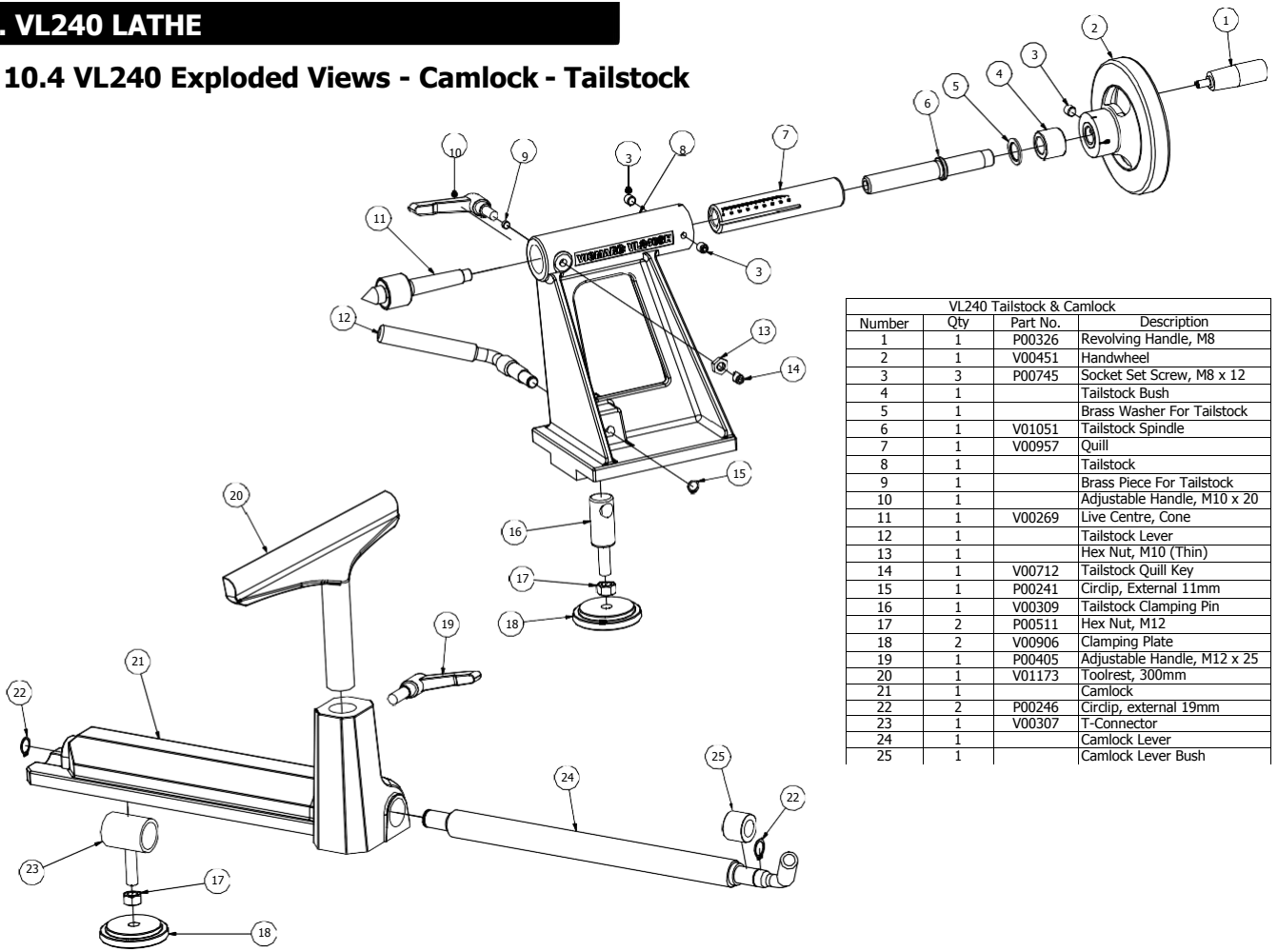

VL240 Tailstock & Camlock			
Number	Qty	Part No.	Description
1	1	P00326	Revolving Handle, M8
2	1	V00451	Handwheel
3	3	P00745	Socket Set Screw, M8 x 12
4	1		Tailstock Bush
5	1		Brass Washer For Tailstock
6	1	V01051	Tailstock Spindle
7	1	V00957	Quill
8	1		Tailstock
9	1		Brass Piece For Tailstock
10	1		Adjustable Handle, M10 x 20
11	1	V00269	Live Centre, Cone
12	1		Tailstock Lever
13	1		Hex Nut, M10 (Thin)
14	1	V00712	Tailstock Quill Key
15	1	P00241	Circlip, External 11mm
16	1	V00309	Tailstock Clamping Pin
17	2	P00511	Hex Nut, M12
18	2	V00906	Clamping Plate
19	1	P00405	Adjustable Handle, M12 x 25
20	1	V01173	Toolrest, 300mm
21	1		Camlock
22	2	P00246	Circlip, external 19mm
23	1	V00307	T-Connector
24	1		Camlock Lever
25	1		Camlock Lever Bush

10.4 VL240 Exploded Views - Motor Mount

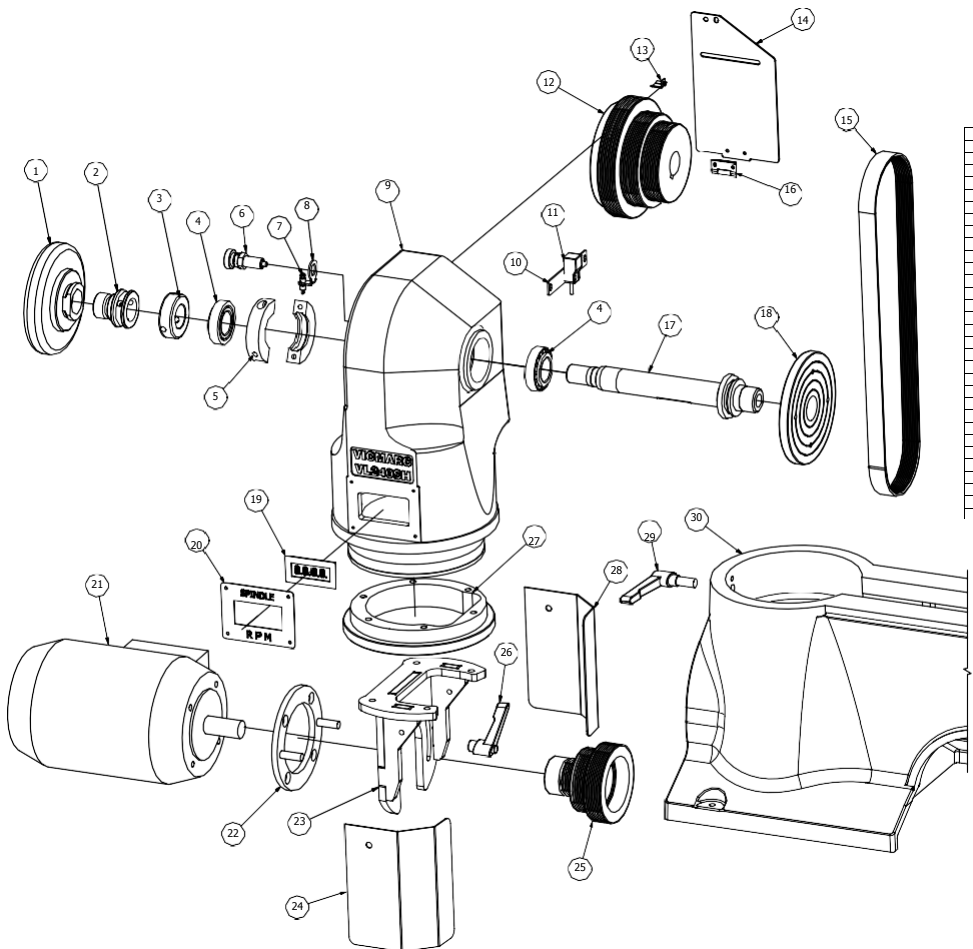

VL240 Headstock & Motormount			
Number	Qty	Part No.	Description
1	1	V00446	Handbrake Wheel
2	1	V00013	Rear Spindle Adaptor
3	1	V00851	Bearing Adjustment Nut
4	2	P00072	Bearing Taper Roller - LM67/048R
5	1	V00975	Sarley Collar
6	1		Headstock Indexing Pin
7	1		Indexing Pin Limit Switch
8	1		Limit Switch Washer
9	1		Headstock
10	1		RPM Sensor Bracket
11	1		RPM Sensor
12	1		Headstock Pulley
13	1		RPM Sensor Indicator
14	1		Headstock Cover
15	1		Belt, Poly-V (see specifications)
16	1		Headstock Cover Hindge
17	1	V01043	Headstock Spindle
18	1	V00411	Faceplate, 100mm
19	1		RPM Display
20	1		RPM Display Cover
21	1		Motor (see specifications)
22	1		Motor Mount Flange
23	1		Motor Mount Bracket
24	1		Motor Pulley Cover Right
25	1		Motor Pulley
26	1	P00396	Adjustable Handle, Female M8
27	1	V00965	Headstock Retaining Ring
28	1		Motor Pulley Cover Left
29	1	P00405	Adjustable Handle, M12 x 25
30	1		Bed

10. VL240 LATHE

10. VL240 LATHE

10.4 VL240 Wiring Diagram

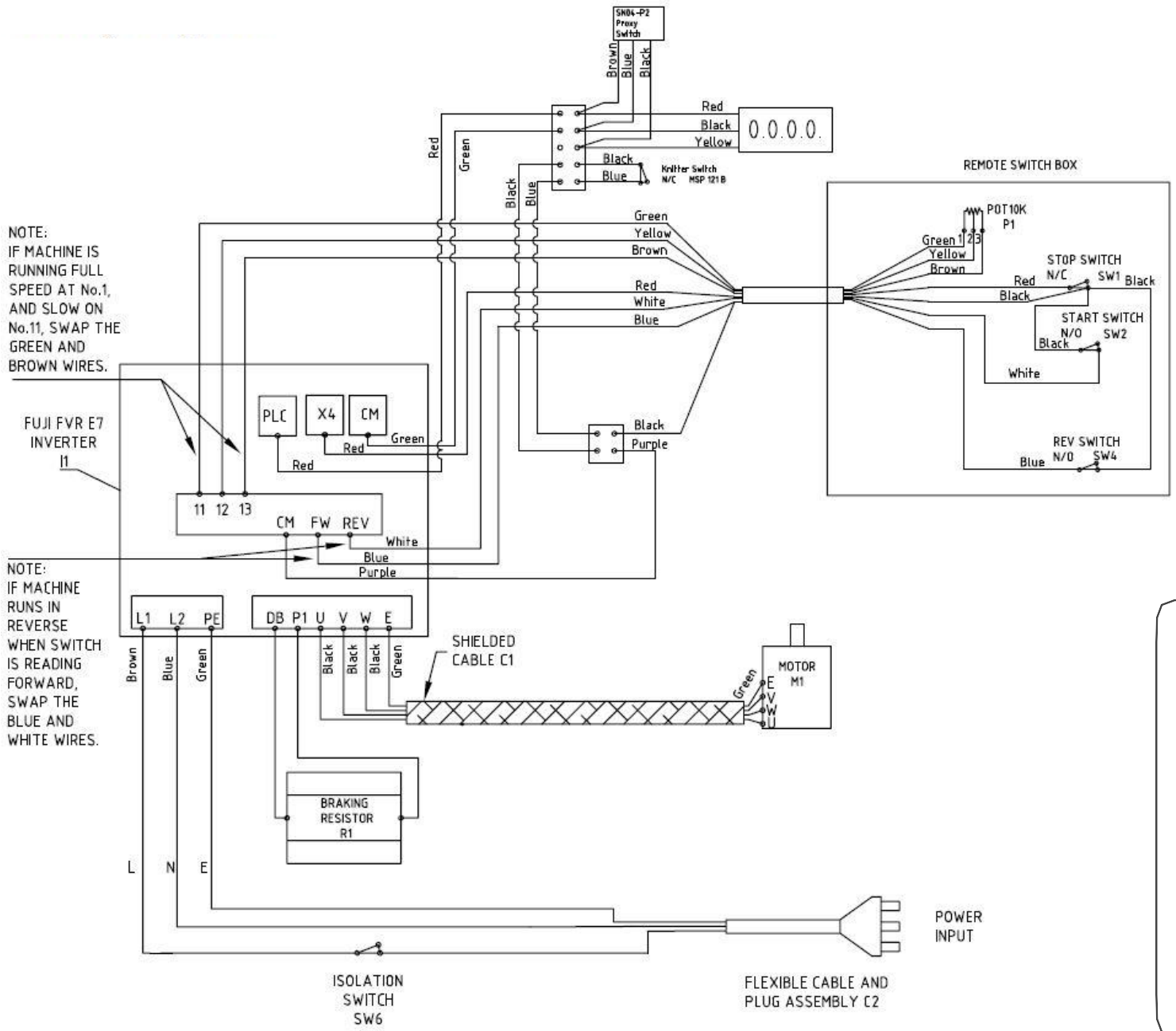

10. 240 LATHES

11. VL200/VL300 LATHES



Lathe Models VL200, VL300 are equipped with the same headstock spindle, tailstock spindle, handwheels, handbrake wheels and bearings. Therefore all adjustments and assembly methods on the headstock and the tailstock on those models are the same. The camlock assemblies are of the same system but different sizes.

11.1 Spindle Pulley Speeds

It is important that the belt is on the right pulley for the speed required. Not doing so can cause the motor to overheat. Below is a representation of the headstock pulleys and their equivalent ratio's.

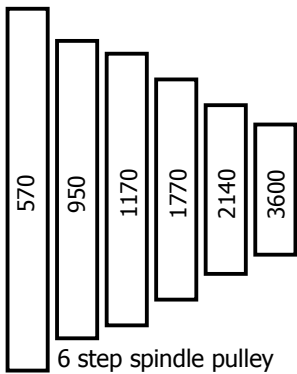

6 step spindle pulley (based on 1500rpm motor)

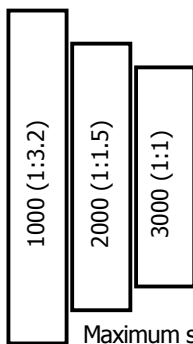

Maximum speed for the three step pulley (based on electronic models)

Readout	Pulley Ratio		
	1:1	1:2	1:3.2
3000	3000	2040	938
2500	2500	1700	782
2000	2000	1360	625
1500	1500	1020	469
1000	1000	680	313
500	500	340	156
250	250	170	78
100	100	68	31
30	30	20	9

11. VL200/300 LATHES

11.2 VL200/300 Exploded Views - Tailstock

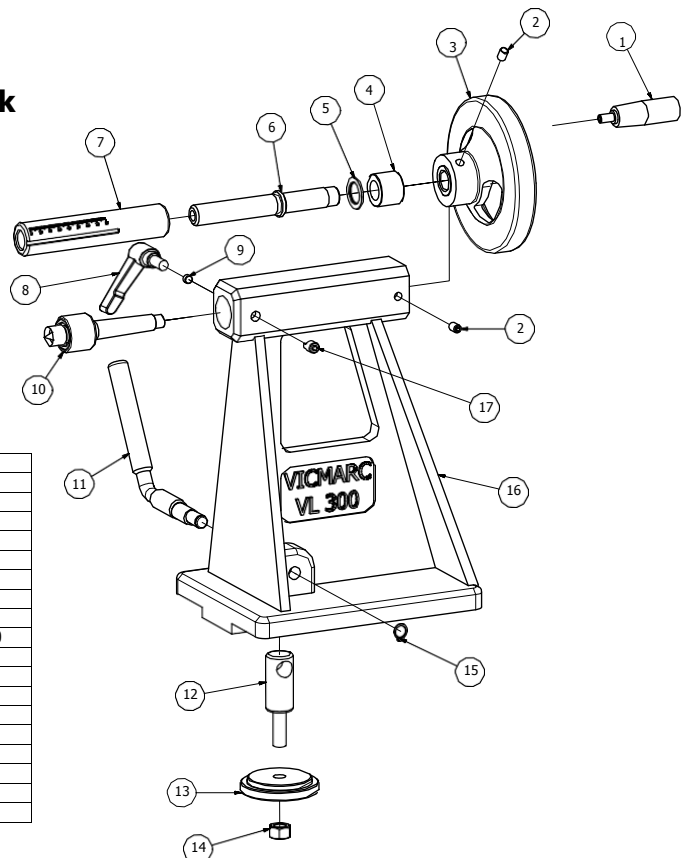

VL200/300 Tailstock				
Number	Qty	VL200 Part No.	VL300 Part No.	Description
1	1	P00326	P00326	Revolving Handle, M8
2	3	P00745	P00745	Socket Set Screw, M8 x 12
3	1	V00451	V00451	Handwheel
4	1			Tailstock Bush
5	1			Brass Washer For Tailstock
6	1	V01051	V01051	Tailstock Spindle
7	1	V00957	V00957	Quill
8	1	P00401	P00401	Adjustable Handle, M10 x 20
9	1			Brass Piece For Tailstock
10	1	V00270	V00270	Live Centre, Cup
11	1	V00803	V00803	Tailstock Lever
12	1	V00309	V00309	Tailstock Clamping Pin
13	1	V00906	V00906	Clamping Plate, 62mm
14	1	P00511	P00511	Hex Nut, M12
15	1	P00241	P00241	Circlip, External 11mm
16	1	V00235	V00236	Tailstock
17	1	V00712	V00712	Tailstock Quill Key

11. VL200/300 LATHES

11.2 VL200/300 Exploded Views - Camlock

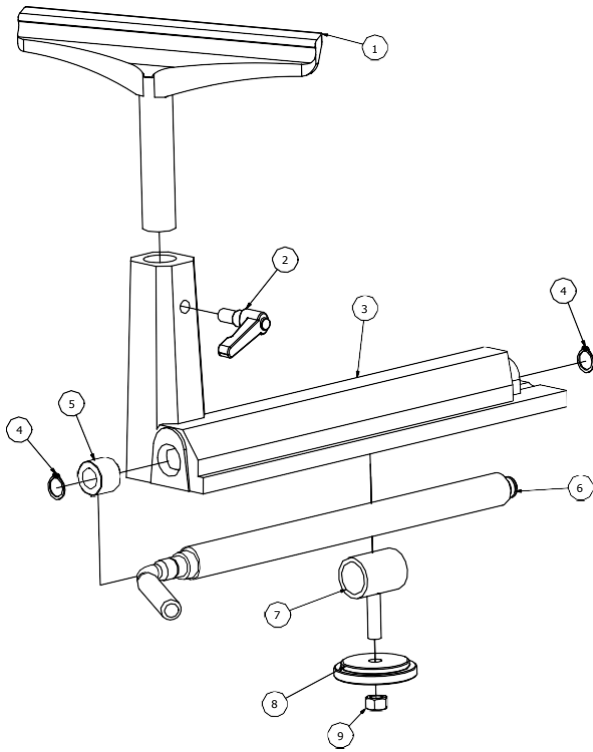

VL200/300 Camlock				
Number	Qty	VL200 Part No.	VL300 Part No.	Description
1	1	V01195	V01195	Toolrest, 300mm
2	1	P00405	P00405	Adjustable Lever, M12 x 25
3	1	V00197	V00198	Camlock
4	2	P00246	P00246	Circlip, External 19mm
5	1	V00148	V00149	Camlock Lever Bush
6	1	V00791	V00792	Camlock Lever
7	1	V00306	V00307	T-Connector
8	1	V00906	V00906	Clamping Plate, 62mm
9	1	P00511	P00511	Hex Nut, M12

11.2 VL200/300 Exploded Views - Headstock

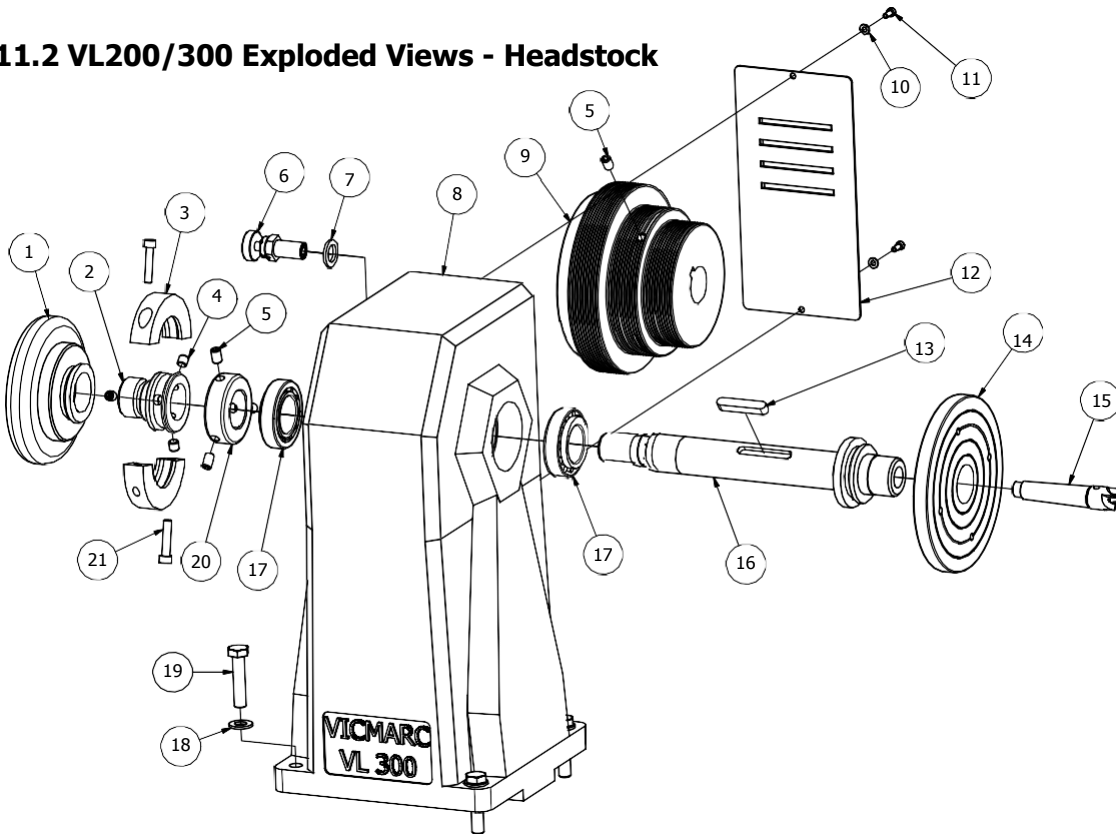

VL200/300 STAND				
No.	Qty	VL200 Part No.	VL300 Part No.	Description
1	1	V00446	V00446	Handbrake Wheel
2	1	V00013	V00013	Rear Spindle Adaptor
3	1	V00975	V00975	Safety Collar
4	3	V00743	V00743	Socket Set Screw, M8 x 8
5	4	V00745	V00745	Socket Set Screw, M8 x 12
6	1	V00881	V00881	Indexing Pin Assembly
7	1	P01195	P01195	Washer, M14
8	1	V00214	V00215	Headstock
9	1	P00938	V00938	Headstock Pulley
10	2	P01194	P01194	Washer, M4
11	2	P00731	P00731	Socket Head Cap Screw, M4 x 10

VL200/300 STAND				
No.	Qty	VL200 Part No.	VL300 Part No.	Description
12	1	V00324	V00324	Headstock Cover
13	1	V00710	V00710	Key, Headstock Spindle
14	1	V00412	V00413	Faceplate
15	1	V00341	V00341	Drive Dog, Heavy Duty
16	1	V01043	V01043	Headstock Spindle
17	1	P00072	P00072	Bearing Taper Roller-LM67048R
18	4	P01203	P01203	Washer, M10
19	4	P00143	P00143	Hex Head Bolt, M10 x 45
20	1	V00851	V00851	Bearing Adjustment Nut
21	2	P00733	P00733	Socket Hd Cap Screw, M6 x 25

11. VL200/300 LATHES

11. VL200/300 LATHES

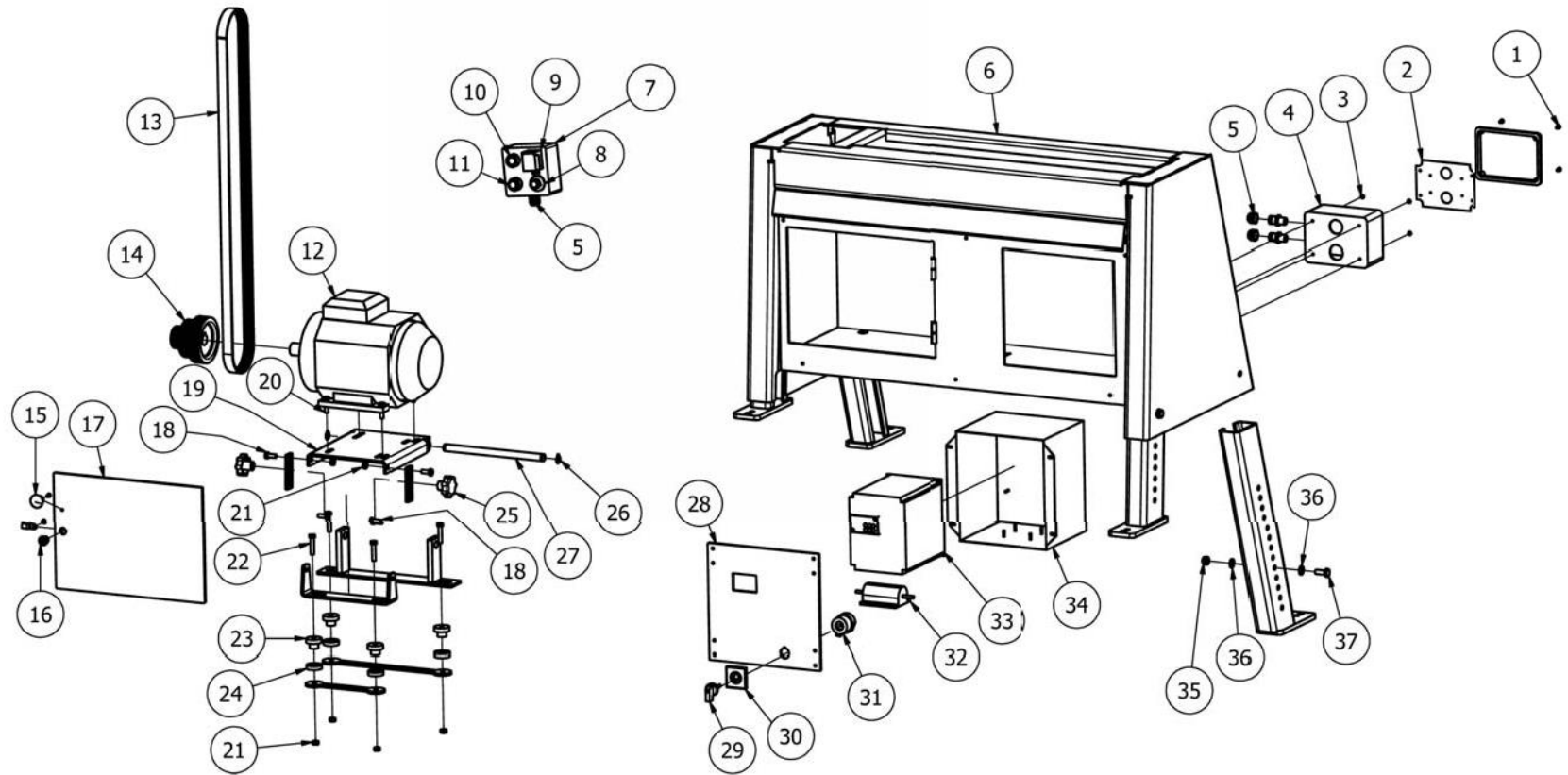

11.2 VL200/300 Exploded Views - Stand

VL200/300 STAND				
Number	Qty	VL200 Part No.	VL300 Part No	Description
1	4			Junction Box Screws
2	1			Electrical Box Inner Plate
3	4	P00701	P00701	Pan Head Screw, M5 x 20
4	1			Junction Box
5	3	P00210	P00210	Cable Gland, 16mm
6	1	-	-	Stand Assembly
7	1	P00180	P00180	Remote Switch Box
8	1	P00631	P00631	Speed Controller
9	1	P00642	P00642	Reverse Button
10	1	P00641	P00641	Start Button
11	1	P00640	P00640	Stop Button
12	1	P00465	P00466	Motor
13	1	P00090	P00091	Belt Poly V - J10-690
14	1	V00939	V00939	Motor Pulley
15	1			Motor Door Knob
16	1			Motor Door Latch
17	1	-	-	Motor Door
18	4	P00130	P00130	Bolt, M8 x 20

VL200/300 STAND				
Number	Qty	VL200 Part No.	VL300 Part No	Description
19	1	-	-	Motor Mount Plate
20	4	P00133	P00133	Bolt, M8 x 30
21	6	P00509	P00509	Nut, M8
22	4	P00135	P00135	Bolt, M8 x 45
23	4	V00846	V00846	Motormount Bush, Male
24	4	V00845	V00845	Motormount Bush, Female
25	2	P00351	P00351	Star Knob Female, M8
26	2	P00244	P00244	External Circlip, 16mm
27	1	-	-	Motormount Shaft
28	1	-	-	Inverter Door
29,30 & 31	1	P01111	P01111	Main Switch Assembly
32	1	P00650	P00650	Breaking Resistor
33	1	P00346	P00343	Inverter
34	1	P00195	P00195	Electronic Box
35	4	P00518	P00518	Nylock Nut, M10
36	8	P01203	P01203	Washer, M10
37	4	P00157	P00157	Bolt, M10 x 25

12. VL200/VL240/VL300 LATHES

12.1 Setting Up The Tailstock

The eccentric locking mechanism of the tailstock is factory preset. If adjusting is necessary the following steps are applicable.

- Slide tailstock to the end of the bed as illustrated.
- Undo the M12 locking nut (anticlockwise is tightening and clockwise is loosening) with an 18mm open end spanner, then rotate the clamping plate clockwise to tighten.
- Lock the Tail stock with locking lever, if lever is in the correct position is at eleven o'clock Re-lock the locking nut.



12.2 Ejecting the Morse Taper

The taper can be ejected a few ways depending on which is applicable

- Quickly turn and pull the taper out.
- Turn the hand wheel anti-clockwise until the taper is ejected.
- When the MT2 taper is shorter than the standard taper they must be knocked out using the knock out bar supplied. Lightly tap the bar while holding the taper (to prevent the taper from falling to the ground).



12.3 Servicing the Tailstock Removing the Quill on the Tailstock

- Lock the tailstock onto the bed using the locking lever.
- Turn the hand wheel so that 20-25mm of the quill is protruding from the front of the tailstock.
- Loosen the grub screws on the handwheel two or three revolutions.
- Using a rubber hammer, tap off the hand wheel.
- Loosen the two grub screws at the rear end of the tailstock two revolutions.
- **Note.** Do not adjust the screws at the side of the tailstock as these are factory set. (Quill keyway will be damaged if these screws are adjusted)
- Mark the quill to ensure that it is replaced exactly as it was prior to removal.
- Lightly tap the front of the quill with a rubber mallet as show in fig. 3.
- The quill can now be cleaned along with the inside of the tailstock.
- **Note.** Never use sandpaper to clean the quill and take care not to remove the brass cylinder at the end of the locking lever while cleaning.
- All mobile parts should now be greased with a high quality grease or graphite grease before re-assembly.

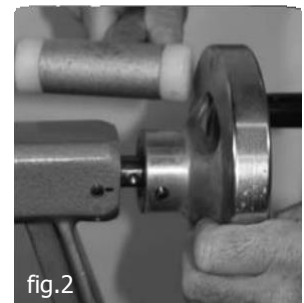

Note. Do not adjust the screws at the side of the tailstock as these are factory set.



12. VL200/240/300 LATHES

Re-Assembling the Quill on the Tailstock:

- The quill should be re-placed from the back of the tailstock making sure that it is horizontal to the bore.
- Push the quill back into place and align with the markings that were made before removal.
- Alternately tighten the two grub screws that hold the quill in place (do not over tighten).
- Replace the hand wheel and tighten the grubscrews.
- Turn the hand wheel. If it doesn't run smoothly (i.e. slight gripping or scraping) several light taps on the hand wheel with rubber hammer will bring the quill into alignment.
- The free play of the hand wheel should be no more than 10 degrees.

12.4 Setting Up The Camlock

The eccentric locking mechanism of the Camlock is factory preset. If adjusting it is necessary the following steps are applicable.

- Remove Tailstock than slide Camlock to the end of the bed as illustrated.
- Undo the M12 locking nut (anticlockwise is tightening and clockwise is loosening) with an 18mm open end spanner, then rotate the clamping plate clockwise to tighten.
- Lock the Camlock with locking lever, if lever is in the correct position is at four or eight o'clock, relock the locking nut. (Camlock is designed to lock in both directions).

12.5 Servicing the Camlock

- Undo the two circlips (one on the lever side one on the rear).
- Reach underneath and support the clamping plate.
- Slide out the camlock bar.
- Thoroughly clean the shaft and the bore.
- Re-grease the shaft with a high quality bearing grease.
- To re-assemble, slide in the shaft through the bore and the camlock T-Connector.
- Replace the circlips.

12.6 Setting up the Safety Ring

When using the lathe in reverse use safety ring to prevent the workpiece from unscrewing itself off the lathe. The following step is applicable when relocating the safety ring.

- Remove safety ring from outboard side of the headstock with 5 mm Allen key provided and re-install the safety ring on the inboard side of the Headstock as shown.

12.7 Changing the Belt Ratio

Depending on the size of the work piece to be turned (see Turning Diameter and Turning Speeds Page 6) the belt ratio may require changing for different speeds.

- Before commencing any maintenance work with the machine, make sure that the mains switch is in the off position.
- Open the motor door at the front of the lathe.
- Loosen the two star knobs on either side of the motor cradle.
- Move the motor slightly upwards to loosen the belt and tighten one of the star knobs to hold it in place.
- Once loosened seat the belt precisely on the correct pulley ratio.
- Loosen the star knob to allow the motor to drop down then retighten both star knobs.

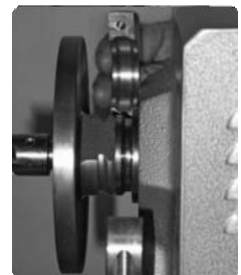

- Check the tension of the belt. It should have a maximum deflection of 10-15mm (do not over tighten as it can cause motor bearing problems) see page 17.
- Close the front door. (The front door has a limit switch so the machine will not start if left open)



12. VL200/240/300 LATHES

12.8 Mounting and Removing the Chuck

Mounting

Before mounting the chuck, make sure that the threads are clean and free of grit.

- To mount the chuck on the lathe, carefully place the chuck on the thread with your right hand, making sure it is square.
- Turn the hand wheel slowly with your left hand to screw on the chuck until it is tight.
- The machine should never be turned on for this procedure.
- If the chuck is too heavy for this procedure then the indexing pin should be engaged and the chuck slowly turned with both hands until it is tight.

Removing

- To release the chuck first ensure that the safety ring has been removed and engage the indexing pin.
 - Place the Allen key into the chuck.
 - Use a light tap with the hand or a soft mallet (never use a metal one) to unbind the thread.
 - Remove the Allen key and unwind the chuck using the hand wheel.
- **Tip:** If you have continued problems removing the chuck, a thin pvc (nylon) washer can be between the face of the chuck and the face of the spindle before the chuck is screwed on. This prevents metal to metal binding which can make it difficult to remove the chuck.



12.9 Outboard Turning Set Up

For outboard turning, the handbrake wheel needs to be removed - to do so:

- Remove the safety ring.
- Engage the indexing pin.
- Loosen the handbrake wheel in an anticlockwise direction using the spanner provided then unscrew the handbrake wheel.
- Screw the handbrake wheel onto the opposite (inboard) side of the lathe and tighten with the spanner provided.



Important Note

Before all outboard turning ensure that the 3 steps (below) have been completed.

Step 1. Before turning large pieces it is recommended to put the ratio 1:3

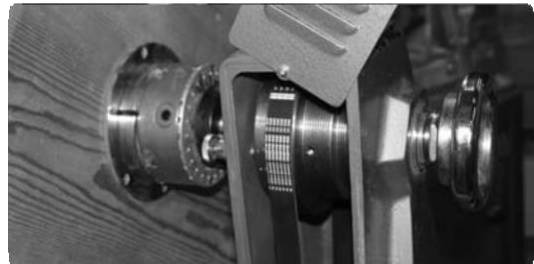

Step 2. clamp the workpiece

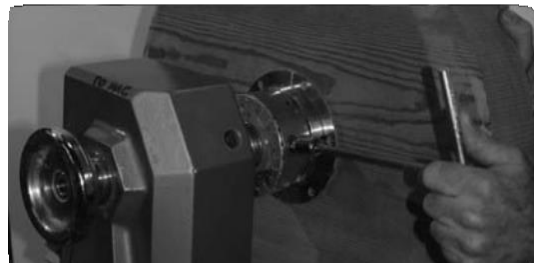

Step 3. Mount the Safety Ring



12. VL200/240/300 LATHES

12.10 Replacing the Belt VL200, VL240, VL300

All Vicmarc® lathes are factory installed with high quality belts, which give many years of service before requiring replacement.

Removing the Belt:

- Make sure that the lathe is turned off at the mains switch.
- Remove safety ring.
- Measure the distance between the largest pulley and the inside of the headstock so that the pulley can be re-installed at the exact same original position.
- Loosen the belt as per changing the belt ratio.
- Loosen the grub screws on the rear spindle adaptor.
- Engage the indexing pin and unscrew the handbrake wheel anti-clockwise and remove.
- Loosen the three grub screws in the thrust ring and remove.
- Loosen the grub screw on the headstock pulley with a 4mm allen key.
- From the hand wheel side, lightly tap the spindle with a rubber mallet (or nylon hammer) making sure that it stays horizontal. It is important to make sure that the spindle keyway is in the vertical position so that it can pass through the keyway opening. (see picture 5).
- Ensure that the taper roller bearing on the handbrake wheel side does not fall out.
- Remove the spindle ensuring that the pulleys are not allowed to drop (caution the pulleys are cast iron and are heavy).
- Place the spindle in a clean place and pull out the pulley wheels.
- The belt can now be removed, making way for a new belt.

Re-Assembly

- Sit the new belt on the pulley & place back into headstock.
- When re-inserting the spindle, make sure that the key on the spindle lines up with the keyway to avoid any damage.
- Line up the pulley back in its original position and re-tighten the grub screw in the middle pulley.
- Screw the thrust ring back on until there is no axial play in the spindle and tighten the grub screws.
- Screw the handbrake wheel back on.
- Hook belt around the motor pulley and tighten the belt adjustment. Check the belt deflection to ensure the correct tension. (see page 17)
- Once assembled replace all covers, disengage the indexing pin and turn spindle by the hand wheel to check for hard spots.
- Turn the machine on at the mains switch and run the machine at moderate Rpm (approx 1500 rpm) for five minutes to check the operation of the machine.
- If the pulley housing gets hotter than luke warm to touch after 5 minutes of operation then stop the machine, loosen the thrust ring grub screws and unscrew the thrust ring approx 2 to 5 degrees then re-tighten the grub screws.



1.



2.



3.



4.

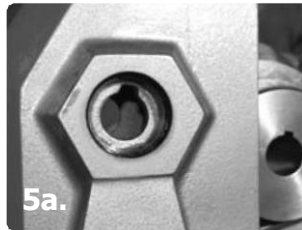

5a.



5.



6.



7.



1.

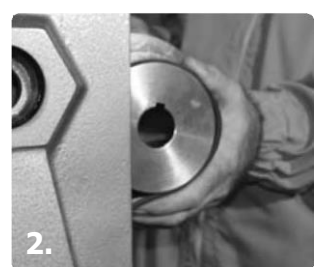

2.

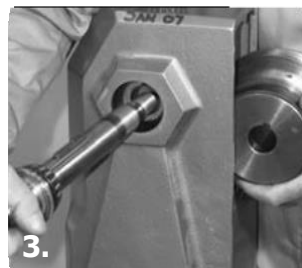

3.



4.



5.



6.



7.

12. VL200, 240, 300 LATHES

13. TROUBLESHOOTING

Problem	Solution
A knocking noise can be heard when the machine is running.	Wood splinters or some other foreign object has contaminated the pulleys or the V-belt. Turn off main switch and remove contaminants. Or A grub screw could have come loose on headstock pulley or motor pulley. Locate and retighten the grub screw.
The speed controller is not responding correctly.	The controller is dusty or there is some moisture build up. Turn off the machine and rotate the speed controller knob a few times or blow out with compressed air.
The machine will not turn on or start.	Make sure the red stop bar is pulled all the way out and isn't stuck in. Also make sure the doors are closed so that all the limit switches are activated.
Belt making screeching noise or jumping off the pulley.	Belt not in line, rubbing up against the face of the pulley. Re-align the belt making sure the motor pulley is in line and square with the headstock pulley.
RPM of the spindle is fluctuating.	Potentiometer could be faulty and should be replaced. Or The electrical unit functions have been altered.
Machine is vibrating.	The machine may be resting on two or three points on the feet causing the machine to oscillate. Re-level the machine so all four feet are supporting the machine pack the feet if necessary to keep level.
The headstock and tailstock are not in alignment.	If you machine is bolted down make sure the floor is level as uneven ground can cause the bed to twist thus putting the headstock and tailstock out of alignment. Or The tailstock or the live center is not sitting level on the bed. Remove the tailstock and make sure the bed slides are clean. Then remove the live centre and wipe down to remove any debris from the Morse taper.
The electronic unit overloads when slowing down the speed on the lathe or stopping the lathe.	When turning large work pieces and you slow down too fast or stop the lathe, the electrical unit tries to slow down the piece of wood. The momentum of the wood generates power, which feeds back into the inverter. If too much power is generated then it gets past the breaking resistor and can cause the unit to overload. Try slowing down the lathe at a slower rate then stopping the lathe at a slower speed to help stop it from overloading.
Tailstock spindle seizing up when drilling through the centre with Auger.	Retract the quill as far back as possible. This preventing saw dust from entering the spindle. To clear the sawdust, blow out with compressed air.

Symptoms of Loose or Broken Wiring

Problem	Solution
Will not start or intermittent start. Once started will maintain direction.	White Wiring broken/loose.
No Reverse starting. However, if starting has occurred, reverse will be maintained until stop command is given.	Blue Wiring broken/loose.
Will not start unless green button is continually pressed. Also intermittent stopping for no reason.	Red Wiring broken/loose.
Will make lathe stop. If wiring is loose, re-start may be possible. This symptom can be erratic or intermittent.	Black Wiring broken/loose.
Lathe will accelerate to 30rpm and stay there. If connection is loose, speed will fluctuate between set speed and 30rpm.	Yellow Wiring broken/loose.
Lathe will accelerate from set speed to maximum speed 3000rpm. If connection is loose, speed will fluctuate or be erratic between set speed and 3000rpm (Max).	Green Wiring broken/loose

Model	Center Height	Swing over Bed"	Distance Between Centres"	Work Height	Indexing Holes"	Spindle Taper	Spindle Bearings	Spindle RPM	Motor kW	RPM Digital Readout	Toolrest Post Diameter	Hole Through Headstock Spindle	Hole Through Tailstock Spindle	Quill Travel
VL150 BM	152mm	304mm	350mm	-	24	MT2	Tapered Roller	6 Speed	-	-	25.4mm	10.5mm	10.5mm	65mm
VL150 SM	152mm	304mm	350mm	-	24	MT2	Tapered Roller	EVS 30-3000	0.75	Inverter Only	25.4mm	10.5mm	10.5mm	65mm
VL200 BM Short	200mm	400mm	400mm	-	24	MT2	Tapered Roller	6 Speed	-	-	30mm	15mm	10.5mm	75mm
VL200 BM Long	200mm	400mm	1000mm	-	24	MT2	Tapered Roller	6 Speed	-	-	30mm	15mm	10.5mm	75mm
VL200 SM 6SP	200mm	400mm	1000mm	1140mm	24	MT2	Tapered Roller	6 Speed	0.75	Inverter Only	30mm	15mm	10.5mm	75mm
VL200 SM EVS	200mm	400mm	1000mm	1140mm	24	MT2	Tapered Roller	EVS 30-3000	1.5	Inverter Only	30mm	15mm	10.5mm	75mm
VL200 ASM Short	200mm	400mm	400mm	940 - 1240mm	24	MT2	Tapered Roller	EVS 30-3000	1.5	Inverter Only	30mm	15mm	10.5mm	75mm
VL200 ASM Long	200mm	400mm	1000mm	940 - 1240mm	24	MT2	Tapered Roller	EVS 30-3000	1.5	Inverter Only	30mm	15mm	10.5mm	75mm
VL240 BM	245mm	490mm	500mm	-	24	MT2	Tapered Roller	EVS 30-3000	1.5	Spindle RPM	30mm	15mm	10.5mm	75mm
VL240 ASM	245mm	490mm	500mm	1020 - 1200mm	24	MT2	Tapered Roller	EVS 30-3000	1.5	Spindle RPM	30mm	15mm	10.5mm	75mm
VL300 BM EVS	302mm	604mm	500mm		24	MT2	Tapered Roller	3 Speed	-	-	30mm	15mm	10.5mm	75mm
VL300 SM EVS	302mm	604mm	500mm	1136mm	24	MT2	Tapered Roller	EVS 30-3000	1.5	Spindle RPM	30mm	15mm	10.5mm	75mm
VL300 ASM	302mm	604mm	500mm	1060 - 1360mm	24	MT2	Tapered Roller	EVS 30-3000	2.2	Spindle RPM	30mm	15mm	10.5mm	75mm

15. TECHNICAL INFORMATION

MOTOR INFORMATION

Lathe Model	Power (kW)	RPM	Freq (Hz)	Volts (V)	Amps	Vicmarc® Re-Order Code
VL150 BM	No Motor Included - Motor Pulley Hole Diameter 14mm / 5/8" / 19mm					
VL150 SM	0.75	1410	50	280-420	1.5	P00462
VL200 BM	No Motor Included - Motor Pulley Hole Diameter 5/8" / 19mm					
VL200 6SP	0.75	1415	50	240	5.8	P00461
VL200L ASM & VL200 SM	1.5	1445	50	280-420	3.3	P00465
VL200S ASM & VL200 Sit Down	1.5	1445	50	280-420	3.3	P00465
VL240	1.5	1450	50	280-420	3.3	-
VL300BM	No Motor Included - Motor Pulley Hole Diameter 28mm					
VL300S SM	1.5	1445	50	280-420	3.3	P00465
VL300S ASM	2.2	1460	50	280-420	4.8	P00466

BELT INFORMATION

Lathe Model	Type	Section	Ribs	Length (mm)	Vicmarc® Re-Order Code
VL150 BM	Poly-V Belt	J	3	380	-
VL150 SM	Poly-V Belt	J	5	380	P00084
VL200BM	Poly-V Belt	J	6	610	P00088
VL200 6SP	Poly-V Belt	J	6	550	-
VL200L ASM	Poly-V Belt	J	10	610	P00090
VL200S ASM	Poly-V Belt	J	10	610	P00090
VL200L SM & VL200 Sit Down	Poly-V Belt	J	10	550	P00088
VL240	Poly-V Belt	J	9	420	-
VL300BM	Poly-V Belt	J	10	690	P00091
VL300L ASM	Poly-V Belt	J	10	690	P00091
VL300S SM	Poly-V Belt	J	10	610	P00090
VL300S ASM	Poly-V Belt	J	10	690	P00091

HEADSTOCK BEARING SIZES

Lathe Model	Inboard		Outboard	
	Bearing Number	Vicmarc® Re-order Code	Bearing Number	Vicmarc® Re-order Code
VL150 BM	32005	P00071	32004	P00070
VL150 SM	32005	P00071	32004	P00070
VL200BM	LM67048	P00072	LM67048	P00072
VL200 6SP	LM67048	P00072	LM67048	P00072
VL200L ASM & SM	LM67048	P00072	LM67048	P00072
VL200S ASM & VL200 Sit Down	LM67048	P00072	LM67048	P00072
VL240	LM67048	P00072	LM67048	P00072
VL300BM	LM67048	P00072	LM67048	P00072
VL300S SM	LM67048	P00072	LM67048	P00072
VL300S ASM	LM67048	P00072	LM67048	P00072



VICMARC

MACHINERY PTY.LTD.

**Manufacturers of Quality
Woodturning Lathes,
Chucks and Accessories**

Phone (07) 3284 3103 Fax (07)3283 4656
Int Ph 61-7 3284 3103 Int Fax 61-7 3283 4656
Email : vicmarc@vicmarc.com Web www.vicmarc.com
A : 52 Grice Street Clontarf QLD 4019 Australia

CHUCKS



VM100



VM120



SCREW FACEPLATES



ECCENTRIC CHUCK #3

TURNING TOOLS & HANDLES



QUICK RELEASE TOOL HANDLES



FIXED BORE HANDLES



BOWL GOUGES

ACCESSORIES



VACUUM CUPS



SHARK JAWS

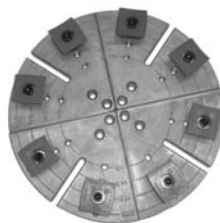

BOWL JAWS



DRIVE DOGS



THREE POINT STEADIES

**SEE OUR
FULL RANGE**

www.vicmarc.com





VICMARC[®] MACHINERY PTY. LTD.

Manufacturers of Quality Woodturning Lathes and Accessories

The Vicmarc[®] Warranty Policy

Vicmarc[®] Machinery Pty Ltd makes every effort to manufacture Vicmarc[®] products to a high quality standard, using the finest materials and up to date manufacturing methods. However, if a customer experiences problems with Vicmarc[®] Products, we must make every effort to remedy the problem.

In the first instance, distributors are responsible to manage warranty issues on behalf of Vicmarc[®] Machinery.

The warranty period for electronics, such as motors and units is 12 months. The warranty period for lathe parts, chucks and accessories is 5 years.

If within the warranty period the product fails due to faulty materials or workmanship, the distributor on behalf of Vicmarc[®] Machinery, will need to arrange for the repair or replacement of faulty items.

The warranty is subject to the following conditions:

- Vicmarc[®] will decline liability if the product has been modified in any way without written authorisation from Vicmarc[®] Machinery
- The warranty is void if the product shows signs of misuse or abnormal over-use i.e. daily heavy duty industrial use.
- The warranty is conditional on the product having been installed and used according to the instruction provided in the owner's manual.
- The product has not been subjected to misuse and or negligence.
- Faulty items will be replaced where possible with an identical item or a suitable substitute.
- Belts are excluded from warranty cover.
- The distributor should retain failed items, as Vicmarc[®] or suppliers to Vicmarc[®] may need them to investigate the cause of failure to initiate improvements.
- Any major replacement of parts and equipment under warranty, resulting in a claim against Vicmarc[®] Machinery, requires prior approval from Vicmarc[®] office before a replacement is agreed to.

Please note:

At times, a judgement call by the distributor may be needed to determine whether there is a genuine case for a claim under warranty.

Lathe Model _____
Serial Number _____
Thread Size _____
Electrical Unit Model _____
Year Of Manufacture _____
Date Of Purchase _____



Each Vicmarc[®] lathe has an identification plate stating the year of manufacture, model number and the serial number. Each Vicmarc[®] Lathe Model has been **CE** certified.

Distributed by:

within Australia 07 3284 3103
overseas +61 7 3284 3103

www.vicmarc.com